

GUANGZHOU CAIZHI LIGHTING TECHNOLOGY CO.,LTD

Professional stage lighting manufacturer





We mainly producing stage lighting, Moving Head Light, Studio light, and LED par light etc. At present, our factory has international advanced technology in stage lighting field which provides with great ability of researching, producing, technical training and contracting great products.

We always exhibiting in Guangzhou GET Show every years, and Shanghai Prolight and sound Exhibition, we will show our new product during the show.



Guangzhou Caizhi Lighting Technology Co.,Ltd is an enterprise which is engaged on stage lights manufacturing. Established in 2010, have more than 50 employees, covers an area of 2000 square meters. our technologist has 13 years production experience. we are a high-tech enterprise integrating with R&D, production, sales and service for the stage lighting products. With advanced technology, excellent quality, stable performance and high quality service, CAIZHI's products have obtained European CE standard and ISO9001.

Our products were saled for State Opera, Vocal concert, State Theater etc. also exported to Europe, the Middle East, North and South America and other regions, and has been got favorable comment by customers at home and abroad.

We accept OEM&ODM service, we have operated with many abroad customer, we keep looking for many client can join in us, we will offer our best quality and serice for you.

Caizhi enterprise will be always holdup the tenet of the quality, service, innovation, and the credibility for the first, target to service the customers and friend for all over the world.





DJ Booth Sytem composed by DJ booth, 4x led moving head light(Bee Eye optional), P17 pixel Screen, easy instal aluminum frame with Transparent acrylic, can be customized with led strip,come with easy fixed 4xwheels. DJ system can be solve small party issure, only one set equipment can meet your party more excite and easy movement events.
Size: 2240x640x1300mm

LY200X is an upgraded LED moving head beam light with high luminous efficiency, small size, fast rotation speed and precise positioning. The case shell is designed with beautiful outline; the double-layer optical lens with high light effect is used to make the beam effect full, straight and bright; the noiseless three-phase motor is used for fast response and accurate positioning; the 8+16 prism + seven color beam effect can be superimposed and flexibly used to make the whole event effect more beautiful.

CZ4019WASH is a super powerful light, compact and unique honeycomb design, use 40w LED, mid-air parallel Beam, uniform Wash and spectacular built-in Graphic effect. Beam zoom from: 6-50°. It features wonderful pixel and ring effect for projection use Shape mode, Individual LED can be controller for benefit for dynamic effect, Front Lens can be rotated bi-directional and continuous effect. Very high-end and powerful ligh

P17 screen composed bright LED, made by 12 pcs 600x300mm module, 16x32 pixels, It can display dynamic images and videos,

LED MOVING HEAD BEAM LIGHT

- Input voltage: AC100-240V 50 / 60Hz
- Rated power: 400W
- Light source: 200W LED
- lamp resource: 50000 hours
- Control mode: Standard 512 DMX protocol, RDM control
- Channel: 15 channels
- Rotation angle: horizontal 540 ° , vertical 270 °
- Color wheel: 1 color wheel with 13 colors
- Gobo wheel: 13 fixed gobo + white.
- Prism: 8+16 facet prism
- Colorful wheel: when the prism is turn on, the superposition of seven color beams is beautiful

Bee Eye Moving Head Light

1. Uniform wash,
 2. mid-air parallel beam,
 3. spectacular built-in graphic effect.
- Voltage Range: 90-240 VAC, 50-60 Hz(auto-ranging)
 - Power consumption: 850W
 - LED resource: 19x40W 4in1 LED
 - Individual LED control Benefit for dynamic effect
 - CTO:Linear controlled 2800-7000k
 - Pixel and Ring effect Shape mode
 - Lens:Front lens bi-directional continuous rotation
 - Wash:0-100% fast linear Frost
 - Zoom:6-50° linear Zoom

Display

- Input: DC 5V
- Pixel: 16x32pixels
- LED quantity:512x 0.3W
- Rate Power: 180W Max
- module size: 600x300mm

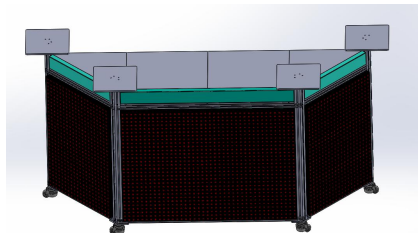

MODEL.: CA700 PROFILE

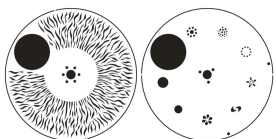

Rotating gobo:



LED FRAMMING 700 is an LED imaging and cutting moving head light, using high-quality 700W LED with high brightness and high power as the light source, combined with the design of high-definition glass optical lenses coated with antireflective film. The beam angle is 6 ° -50 ° linear amplification and reduction function. A set of cutting discs consists of four cutting blades, forming a controllable spot cutting angle system. The entire cutting angle system can rotate 150 °, and through preCaise control of the cutting plate, any shape of the light spot can be created, Dynamic Effect Wheel: Superb simulation of dynamic effects such as moving flames and flowing water; Equipped with a powerful CMY color infinite mixing system, outstanding high color rendering surface light effect, pure color effect, clear imaging gobo, uniform prism effect, and professional dimming control; Suitable for professional theaters, medium to large performances, television stations, and various high demand recording and shooting performance events.

Specification**Light Resource and Power**

- Power Input: AC100~240v, 50/60Hz
- Power Consumption: 1100W
- Light source: brightness 700w LED
- Rated life: 20000 hours
- Color temperature: 6000K
- Focus adjustment: high precision glass lens, 6 ° to 50 ° linear high-speed zoom, uniform spot in any range

Cutting system

A set of omni-directional graphics cutting system can generate geometric figures of different sizes and shapes, and the graphics can be rotated at any angle from 0 ° to 150 °

Pattern system

- Rotating gobo: one rotating gobo wheel has 6 exchange gobo+ open, which can be vibrated and rotated in both directions with 16bit precision fine adjustment.
- Fixed gobo: one fixed gobo wheel has 8 gobo, which can be vibrated and rotated in both directions.
- Effect wheel: a dynamic effect wheel, which can simulate the dynamic effects of flame and water

Color system

- CMY infinite color mixing.
- CTO linear color temperature adjustment.
- Color wheel: one color disc has 7 kinds of color wheel, which can realize bidirectional rainbow effect, half color and linear adjustment.

Software and control

- Control channel: 21/40 CH
- Transmission protocol: DMX512, RDM, optional wireless transmission
- Display mode: 2.8 inch color touch screen.

Effect

- Pan/Tilt: Pan 540 °, Tilt 270 °, automatic return correction and 16bit precision fine adjustment function
- Diaphragm: 5-100% linear adjustment, with a variety of macro function effects
- Strobe: 1-25hz fast electronic strobe per second, with pulse stroboscopic, synchronous asynchronous stroboscopic effect
- Dimming: 0-100% electronic linear dimming
- Prism: one 3-facet prism, one 4-facet linear prism, two prisms can be superimposed, can rotate in two directions
- Atomization: 1 independent atomization
- Fingertip: a separate fingertip lens
- Weight: 35kg
- Protection grade: IP20

MODEL: CA500 PROFILE

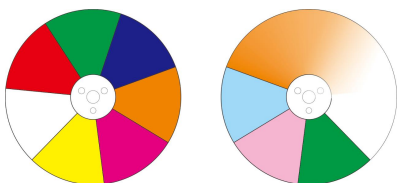
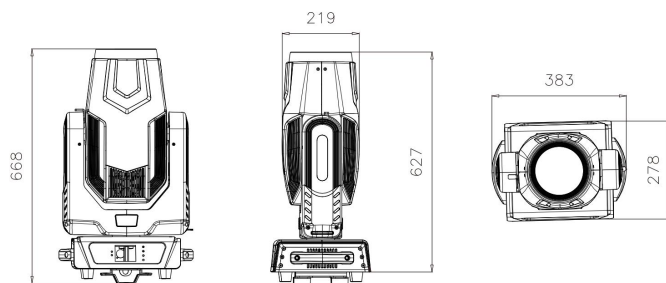

Technical parameters:

Input Voltage:100-240V AC, 50/60Hz
Power Consumption:700W@220V

Light Source: 500w led light source (8500k, 5000hrs)

Strobe: Double shutter blades. 0.5-14. F.P.S

Dimmer: 0-100% linearly adjustable

Colors

CTO 2800-6500K+ color mixing system

1 Color wheel: 6 colors+, plus open

Rainbow effect with bi-directional and variable speeds

Stepping/linear color changing

Gobo

Rotating gob wheel: 7 interchangeable gobos plus open

Bi-direction rotating at variable speeds

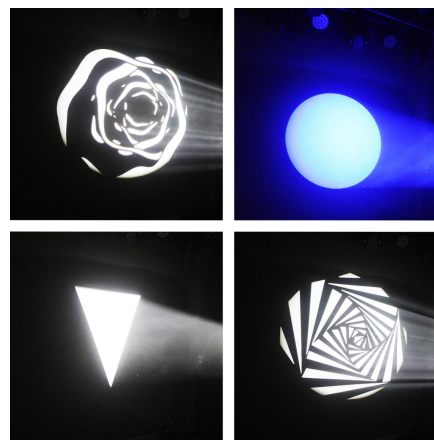

Focus: DMX linear focus, the gobo can be intelligent auto focus

Zoom: DMX linear zoom

Head Movement: Pan 540, Tilt 245 degree with auto position correction

Light Angle10° - 45°

Control

International DMX512, 3 pin (5 pins interface optional)

Auto mode

Other Functions

Adjustable pan & Tilt speed

LCD display screen

Silence Fans control system

Modular structure for easy maintenance

Physical

Housing: high temperature engineering plastic, IP20

Ambient temperature: Maximum 45 C

Clamp: built-in aluminum two G clamp, easy for hung up.

Net weight: 22.5kg

Size: 365 * 290 * 660mm (L * w * h)

MODEL: LY400 BSW CMY

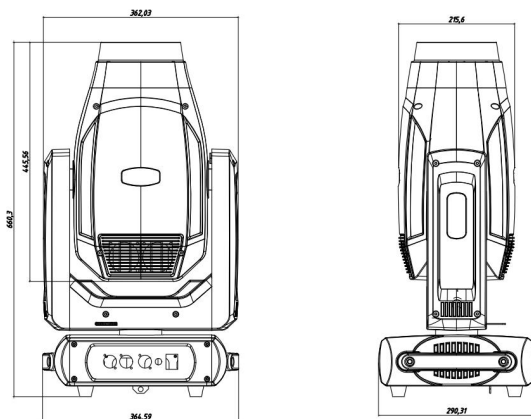

Technical parameters:

Input Voltage:100-240V AC, 50/60Hz
Power Consumption:550W@220V

Light Source: 400w led light source (8500k, 5000hrs)

Strobe: Double shutter blades. 0.5-14. F.P.S

Dimmer: 0-100% linearly adjustable

Colors

CMY color mixing system

1 Color wheel: 9 colors+CTO 2800-6500K, plus open

Rainbow effect with bi-directional and variable speeds

Stepping/linear color changing

Gobo

Fixed gobo wheel: 9 gobos plus open

bi-directionally rotating, and shakable effect at variable speed

Rotating gob wheel: 8 interchangeable gobos plus open

Bi-direction rotating at variable speeds

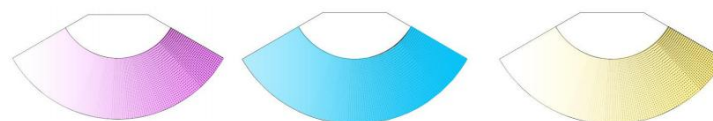

Cyan

Magenta

Yellow

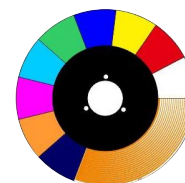
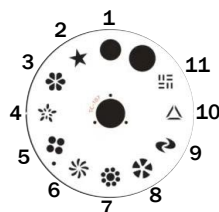

Prism

Two prism(standard: 4-facet circle and 4-facet linear prism

Bi-directional rotation at variable speeds

Frost: one frost filter

Focus: DMX linear focus, the gobo can be intelligent auto focus

Zoom: DMX linear zoom

Head Movement: Pan 540, Tilt 245 degree with auto position correction

Light Angle

Beam Mode: 2.3° - 10°

Spot mode: 5° - 45°

Wash Mode: 5° - 45°

Control

International DMX512, 3 pin (5 pins interface optional)

Auto mode

Other Functions

Adjustable pan & Tilt speed

LCD display screen

Silence Fans control system

Modular structure for easy maintenance

Physical

Housing: high temperature engineering plastic, IP20

Ambient temperature: Maximum 45 C

Clamp: built-in aluminum two G clamp, easy for hung up.

Net weight: 22.5kg

Size: 365 * 290 * 660mm (L * w * h)

The new hybrid versatile 3in1 luminaire **CA500 BSW CMY** integrates three features(beam, wash, spot)in single unite. It has adopted patented technology CMY color system, combines advanced Osram 420W Lamp technology with superb optional system. it can enhances and show with its massive 2.3 to 40 zoom range, all the function can be mixed with dynamic for amazing effect.

Specifications

Input Voltage:100-240V AC, 50/60Hz
Power Consumption:500W@220V

Light Source: Osram 420W (7500k, 1500hrs)

Strobe: Double shutter blades. 0.5-14. F.P.S

Dimmer: 0-100% linearly adjustable

Colors

CMY +CTO Linear color mixing with macro
1 Color wheel: 13 dichroic color filter(CTO) 2800-6500K, plus open
Rainbow effect with bi-directional and variable speeds
Stepping/linear color changing

Gobo

Fixed gobo wheel: 14 gobos plus open
bi-directionally rotating, and shakable effect at variable speed
Rotating gob wheel: 8 interchangeable gobos plus open
Bi-direction rotating at variable speeds
Dynamic wheel: all function can be mixed for dynamic amazing effect

Prism

Two prism(standard: 8-facet and 16-facet prism
Optional: 3-facet/16-facet linear prism or flower prism
Bi-directional rotation at variable speeds

Frost: one frost filter

Iris: Electric Iris 100%-10%, the beam angle can be adjustable.

Focus: DMX linear focus, the gobo can be intelligent auto focus

Zoom: DMX linear zoom

Head Movement: Pan 540, Tilt 245 degree with auto position correction

Light Angle

Beam Mode: 2.3-10

Spot mode: 1-40

Wash Mode: 5-40

Control

International DMX512, 3 pin and 5 pins interface

Short mode 30channels

self-test mode

Other Functions

Adjustable pan & Tilt speed

LCD display screen

Fixture and lamp hours display

Modular structure for easy maintenance

Interface USB: download the instruction, library, upload

Logo etc.

Physical

Housing: high temperature engineering plastic, IP20

Ambient temperature: Maximum 45 C

Clamp: built-in aluminum two G clamp, easy for hung up.

Weight

Net weight: 23kg

Body size: 42x27x63(cm)

MODEL: CA500 BSW CMY

**BEAM, SPOT, WASH - 3IN1
CMY+CTO**



ROTATING GOBO

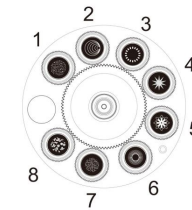

FIXED GOBO



DYNAMIC GOBO



COLOR WOHITE

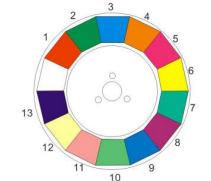

CMY SYSTEM+CTO

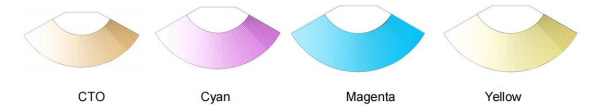

MODEL: CA500 BSW

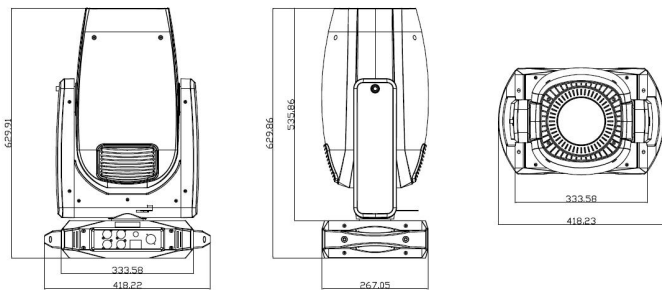

CA500 BSW Moving Head is a Moving Head Light integrates three features(Spot, Wash and Beam) in a single unit. It uses advanced 461W lamp technology to deliver more than 200.000 lux. zoom in/out: 2.3° -50° ,Parallel beam, excellent gobo and mixing colorful wash and prism effect, good for using in Music Festival and church events.

Specifications

Power/Light resource

- Voltage: AC90V~240V/50-60Hz
- Average lifespan:3000 hours
- Power: 650W
- Focus: Linear adjustment
- Lamp: Osram 461W
- Dimmer: 0-100% linear adjustment
- Color temperature:7500K
- Strobe: Mechanical shutter 0.3-25 F.P.S
- Ballast: E-ballast

Color/Pattern/Effect

- Color:14 color + blank color wheel
- Wash effect:Adjustable wash effects angle
- Two prisms:8-facet and 16-facet prisms, bi-directional rotating at variable speeds, prism can be zoom in/out.
- One Fixed gobo wheel: 15 fixed gobo + blank, rainbow and shade effect
- One Rotating gobo wheel: 9 interchange gobo + blank, rotating and gobo position effect.

Light Angle

- Beam Mode: 2.3° -10°
- Spot mode: 2.3° -50°
- Wash Mode: 5° -50°

Control system

- Control mode: DMX/ART-NET/RDM/Single Mode/Master/Slave mode
- Channel: 20 in standard mode and 24 in extended mode
- Time function: Menu record overall operate time and working time of light and lamp
- Pan: 540° ; Pan: 239° , automatically accurate positioning
- The menu display 16 million pixel color LCD touch screen; screen can display upright, inverted, and adjust the brightness of the background,
- The intelligent control of the cooling fan (the radiator is completely controlled by the state of the lamp and the requirements for the intelligent control to ensure the service life of the bulb and the normal working state).
- Electronic sensor detection reset error function, automatic correction work
- Modular structure for easy maintenance

Appearance parameter

- High temperature Engineering plastic, IP20
- Net weight: 23Kg
- Body size: 42x27x63(cm)

Rotating Gobo

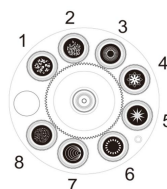

Fix Gobo

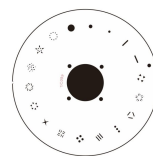

Color wheel



8-facet prism

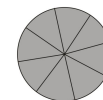

48-facet prism

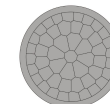

MODEL: X500 SUPER BEAM



X500 Super beam is an upgraded powerful Moving head beam. The case shell is designed with beautiful outline; the double-layer optical lens with high light effect is used to make the beam effect full, straight and bright; the noiseless three-phase motor is used for fast response and accurate positioning; the double prism (8 linear and 16 circle prism. 20 prism optional) + seven color beam effect can be superimposed and flexibly used to make the whole event effect more beautiful.

Technical Parameter

- Optical system
- Light source: Oram 420 W
- Light source life: ≥ 3000h
- Color temperature: 8500K

- Electrical system
- Input voltage: AC100-240V, 50 / 60Hz
- Rated power: 550W
- Power: powercon input / output
- DMX: 3-pin DMX connector input / output

Control

- Channel mode: 15/20 channels
- Control protocol: DMX512, RDM bidirectional data transmission, remote software upgrade
- Operation mode: DMX512 , Master-slave, Auto run

- Display screen: TFT screen, can be inverted 180 ° display

- Effect/Function
- Movement angle: Pan 540 ° , Tilt 270 ° 16 bit precision scanning
- Color: 14 colors + white
- Gobo: 17 gobo+ white
- Prisms: 8 circle facet prism and 16 circle facet prism, can be mixed
- Correction: automatic return correction and 16bit precision fine adjustment function, using digital wave shape correction technology, to ensure accurate positioning of Pan and Tilt, it does not shake after high-speed operation and reset
- Focusing angle: 2
- Dimming: 0-100% linear dimming
- Strobe: 1-25 t/s

Cooling system

- Cooling system: adopt copper tube + fan cooling structure and temperature intelligent temperature control monitoring technology, automatically adjust the cooling system, and effectively control the lamp temperature

Appearance

- Materials: high temperature resistant fireproof plastic + molded alloy material
- Working environment: - 20 °C - 40 °C
- Protection grade: IP20
- Net weight: 18kg

color wheel



6-colorful and frost



fix gob



8-facet prism/48-facet prism

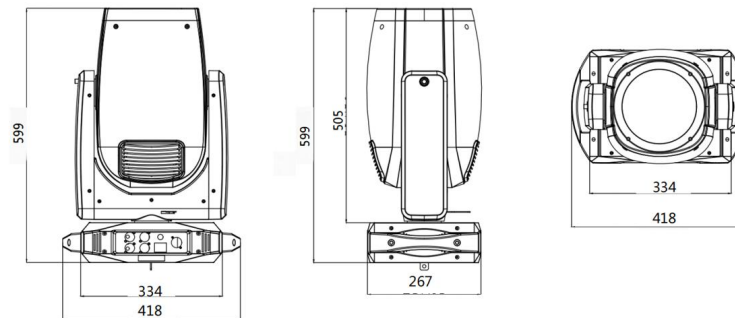
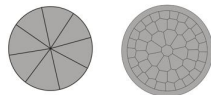

MODEL: CA380 BSW



CA380 BSW Moving Head is a Moving Head Light integrates three features(Spot, Wash and Beam) in a single unit. It uses advanced 461W lamp technology to deliver more than 200.000 lux. zoom in/out: 2.3° -50° ,Parallel beam, excellent gobo and mixing colorful wash and prism effect, good for using in Music Festival and church events.

Specifications

Power/Light resource

- Voltage: AC90V~240V/50-60Hz
- Average lifespan:3000 hours
- Power: 500W
- Focus: Linear adjustment
- Lamp: Philip 350W
- Dimmer: 0-100% linear adjustment
- Color temperature:7500K
- Strobe: Mechanical shutter 0.3-25 F.P.S
- Ballast: E-ballast

Color/Pattern/Effect

- Color:9 color + blank color wheel
- Two prisms:8-facet and 16-facet prisms, bi-directional rotating at variable speeds, prism can be zoom in/out.
- One Fixed gobo wheel: 11 fixed gobo + blank, rainbow and shade effect
- One Rotating gobo wheel: 7 interchange gobo + blank, rotating and gobo position effect.

Light Angle

- Beam Mode: 2.3° -10°
- Spot mode: 2.3° -50°
- Wash Mode: 5° -50°

Control system

- Control mode: DMX/ART-NET/RDM/Single Mode/Master/Slave mode
- Channel: 20 in standard mode
- Time function: Menu record overall operate time and working time of light and lamp
- Pan: 540° ; Pan: 239° , automatically accurate positioning
- The intelligent control of the cooling fan (the radiator is completely controlled by the state of the lamp and the requirements for the intelligent control to ensure the service life of the bulb and the normal working state).
- Electronic sensor detection reset error function, automatic correction work
- Modular structure for easy maintenance

Appearance parameter

- High temperature Engineering plastic, IP20
- Net weight: 20Kg
- Body size: 32x227x590(cm)

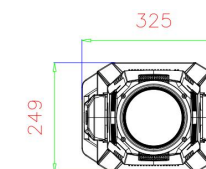
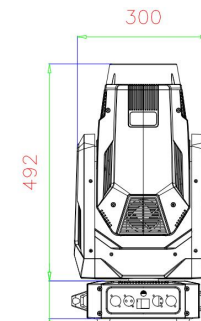
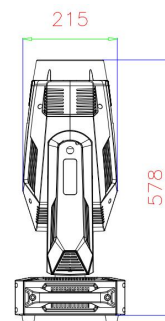

MODEL: CA380 BSW IP



CA380 BSW IP Moving Head is a Moving Head Light integrates three features(Spot, Wash and Beam) in a single unit. It uses advanced 371W lamp technology to deliver more than 200.000 lux. zoom in/out: 2.3° -50° ,Parallel beam, excellent gobo and mixing colorful wash and prism effect, waterproof IP65, good for using in Music Festival and church events.

Specifications**Power/Light resource**

- Voltage: AC90V~240V/50-60Hz
- Average lifespan:3000 hours
- Power: 500W
- Focus: Linear adjustment
- Lamp: OSRAM SIRIUS HRI 371W
- Dimmer: 0-100% linear adjustment
- Color temperature:7500K
- Strobe: Mechanical shutter 0.3-25 F.P.S
- Ballast: E-ballast

Color/Pattern/Effect

- Color: 13 color + blank color wheel
- Two prisms:8-facet and 16-facet prisms, bi-directional rotating at variable speeds, prism can be zoom in/out.
- One Fixed gobo wheel: 13 fixed gobo + blank, rainbow and shade effect
- One Rotating gobo wheel: 7 interchange gobo + blank, rotating and gobo position effect.

Light Angle

- Beam Mode: 2.3° -10°
- Spot mode: 2.3° -50°
- Wash Mode: 5° -50°

Control system

- Control mode: DMX/RDM/Single Mode/Master/Slave mode
- Channel: 20/24 in standard mode
- Time function: Menu record overall operate time and working time of light and lamp
- Pan: 540° ; Pan: 239° , automatically accurate positioning
- The intelligent control of the cooling fan (the radiator is completely controlled by the state of the lamp and the requirements for the intelligent control to ensure the service life of the bulb and the normal working state).
- Electronic sensor detection reset error function, automatic correction work
- Modular structure for easy maintenance

Appearance parameter

- Waterproof level: IP65
- Net weight: 35Kg
- Body size: 47x32x72(cm)

MODEL: CA380 BEAM IP

CF380 BEAM IP is a powerful beam moving head light in outdoor , IP65 waterproof level, It uses low energy consumption Philip 380W as light source and makes the full use of its long life span and high light efficiency. Equipped with 1 fixed gobo wheel, 2 prisms 8+24 can be overlapped, 1 color wheels with 14color, double lens focusing, strobe, coloful wheel and frost filter, it can fulfill lots of functions with amazing effects. It is suitable for medium and large scale events, concerts, stadiums, parties in outdoor, etc.



Color wheel



Fix gobo



colorful and frost



8/24 facet prism

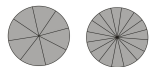

Technical parameter

- Input voltage: AC90-245V 50-60Hz
- Full power: 650W
- Lifetime: more than 3000 hours
- Light bulb color temperature: 7800K
- Focusing: Linear Electric Focusing
- Color temperature: 2500K-7800K are optional.
- Dimmer: linear dimmer without flicker
- Light Source: Philip 380W
- Strobe: 0.5-20 t/s with adjustable speed.

Color/GOBO/effect

- Beam angle: 2 °
- Lens diameter: 190mm
- color: 14 color filter+white, can realize color rainbow effect.
- Fixed Gobo wheel: 17 gobo + open, shaking , animation effect
- 2 Prism 24prism + 8 prism (standard, customizable)
- Effect wheel: Frost+6-colorful
- Control mode: DMX 512, self-propelled, master-slave
- Movement: Pan 540 °, Tilt 275 °, can be positioned automatically.
- Channel: Standard 15 Ch
- Protection Level: IP65
- House Material: High strength PA66, with high temperature resistance, ultraviolet resistance, flame retardant, aging resistance, wear resistance, lightweight anti-fall and other characteristics.
- Light body size: 400*360*720(mm)
- Net weight: 25kg

MODEL: X5 BEAM PLUS



X5 Beam Plus is an upgraded powerful Moving Head Beam with LED pixel pattern effect. The case shell is designed with beautiful outline; the double-layer optical lens with high light effect is used to make the beam effect full, straight and bright; the noiseless three-phase motor is used for fast response and accurate positioning; the double prism (8 linear and 20 circle prism. 48 flower prism optional) + seven color beam effect can be superimposed and flexibly used to make the whole event effect more beautiful.

Feature

- High brightness of **OSRAM SIRIS HRI 311W**
- **LED pixel pattern effect on the head.**
- **Bright sharp beam 165000 Lux @ 20 meter**
- Beam angle is 2 °
- colorful beam with 6colors wheel

Technical Parameter

- Optical system
- Light source: **OSRAM SIRIS HRI 311W and 60x 3in1 LED (pixel)**
- Light source life: ≥ 2000h
- Color temperature: 8500K

Electrical system

- Input voltage: AC100-240V, 50 / 60Hz
- Rated power: 450W
- Power: powercon input / output
- DMX: 3-pin DMX connector input / output

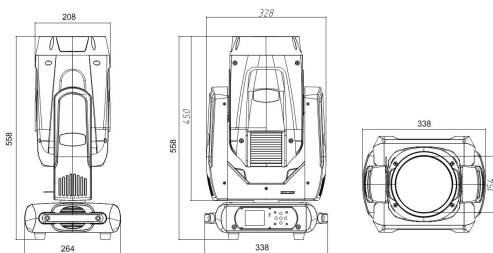

Control

- Channel mode: 24/28 channels
- Control protocol: DMX512, RDM bidirectional data
- transmission, remote software upgrade
- Operation mode: DMX512 , Master-slave, Auto run
- Display screen: TFT screen, can be inverted 180 ° display

Effect/Function

- Movement angle: Pan 540 ° , Tilt 270 ° 16 bit precision scanning
- Color: 14 colors + white
- Gobo: 17 gobo+ white
- Prisms: 8 circle facet prism and 20circle facet prism, can be mixed
- Correction: automatic return correction and 16bit precision fine adjustment function, using digital wave shape correction technology, to ensure accurate positioning of Pan and Tilt, it does not shake after high-speed operation and reset
- Focusing angle: 2
- Dimming: 0-100% linear dimming
- Strobe: 1-25 t/s

Cooling system

- Cooling system: adopt copper tube + fan cooling structure and temperature intelligent temperature control monitoring technology, automatically adjust the cooling system, and effectively control the lamp temperature

Appearance

- Materials: high temperature resistant fireproof plastic + molded alloy material
- Working environment: - 20 °C - 40 °C
- Protection grade: IP20
- Net weight: 15.4kg
- Lamp size: 338x264 × 558mm

MODEL: X400/X450 BEAM



X400 Beam is an upgraded powerful Moving Head Beam. The case shell is designed with beautiful outline; the double-layer optical lens with high light effect is used to make the beam effect full, straight and bright; the noiseless three-phase motor is used for fast response and accurate positioning; the double prism (8 linear and 16 circle prism. 48 flower prism optional) + seven color beam effect can be superimposed and flexibly used to make the whole event effect more beautiful.

Feature

- High brightness of Ushio professional 391W lamp
- LED pixel pattern effect on the head.
- Bright sharp beam 265000 Lux @ 20 meter
- Beam angle is 2°
- colorful rainbow beam effect

Technical Parameter

- Optical system
- Light source: Ushio professional 391W lamp or 420W
- Light source life: ≥ 3000h
- Color temperature: 8500K

Electrical system

- Input voltage: AC100-240V, 50 / 60Hz
- Rated power: 500W
- Power: powercon input / output
- DMX: 3-pin DMX connector input / output

Color wheel



colorful and frost



Fix gobo



8/16 facet prism

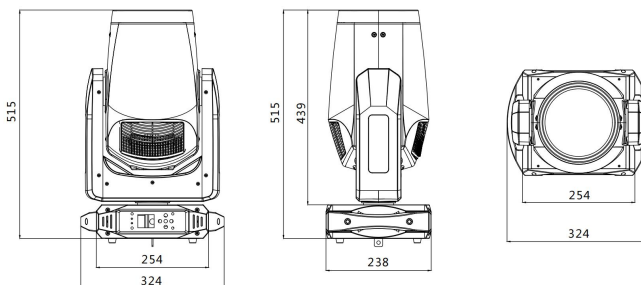
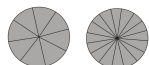

Control

- Channel mode: 15/20 channels
- Control protocol: DMX512, RDM bidirectional data transmission, remote software upgrade
- Operation mode: DMX512, Master-slave, Auto run
- Display screen: TFT screen, can be inverted 180° display

Effect/Function

- Movement angle: Pan 540°, Tilt 270°, 16 bit precision scanning
- Color: 12 colors + white, and with 6-colorful wheel
- Gobo: 17 gobo+ white
- Prisms: 8-facet prism and 16 facet prism, two prism can be mixed
- Correction: automatic return correction and 16bit precision fine adjustment function, using digital wave shape correction technology, to ensure accurate positioning of Pan and Tilt, it does not shake after high-speed operation and reset
- Focusing angle: 2°
- Dimming: 0-100% linear dimming
- Strobe: 1-25 t/s

Cooling system

- Cooling system: adopt copper tube + fan cooling structure and temperature intelligent temperature control monitoring technology, automatically adjust the cooling system, and effectively control the lamp temperature

Appearance

- Materials: high temperature resistant fireproof plastic + molded alloy material
- Working environment: - 20 °C - 40 °C
- Protection grade: IP20
- Net weight: 15.4kg
- Lamp size: 324x238x515mm

MODEL: X3S BEAM

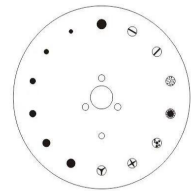
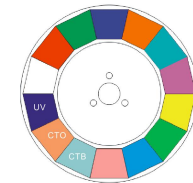
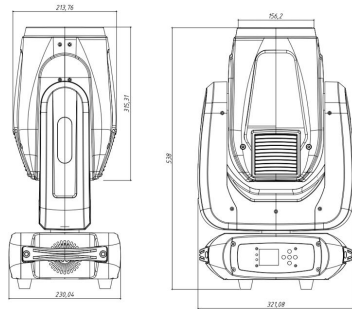

X3S BEAM is an upgraded moving head beam light with high luminous efficiency, small size, fast rotation speed and precise positioning. The case shell is designed with beautiful outline; the double-layer optical lens with high light effect is used to make the beam effect full, straight and bright; the noiseless three-phase motor is used for fast response and accurate positioning; the double prism (8 linear and 8 circle prism. 48 flower prism optional) + seven color beam effect can be superimposed and flexibly used to make the whole event effect more beautiful.

Pure Parallel Beam 0°



Frost Wash 40°



8-Facet Prism 40°



48-facet Prism+colorful wheel 45°



8 facet linear prism and 48-facet prism

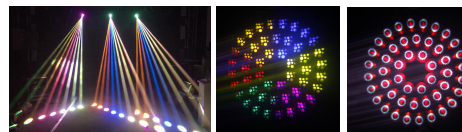

Technical parameters:

Input voltage: AC100-240V 50 / 60Hz

Rated power: 400W

Light source: 8R 250W lamp

Color temperature: 8000K

Bulb life: 2000 hours

Control mode: Standard 512 DMX protocol, RDM control by 3 pin and 5 pin DMX interface

Channel: 15 channels / 18channels

Rotation angle: horizontal 540° , vertical 270°

(16bit precision scanning) electronic error correction

Operation speed: horizontal 2.5 seconds, vertical 1.4 seconds

Co wheel: 1 color wheel with 13 colors(3 glass gobo) + white, with half color effect function

Gobo wheel: 13 fixed gobo (3 glass gobo) + white.

Prism: 8-facet linear prism and a flower prism(i.e. 48 prism), the prism rotates and can be stacked

Frost: soft wash effect

Colorful wheel: when the prism is turn on, the superposition of seven color beams is beautiful

Strobe: two piece stroboscopic 0-13 times / second, adjustable speed

dimming: 0-100% linear dimming

Focus: 0-100% linear focus

Light beam angle: 0-3° parallel beam

0-40° wash beam

0-45° prism beam

Display mode: LCD

USB interface: Put 5V voltage to the screen for adjust the dmx address.

Working environment: 0-40° C

Protection grade: IP20

Cooling: adopt axial fan to strengthen ventilation and cooling

Safety device: with temperature control overheat protection, temperature control automatic power-off protection in case of overheat system failure

Net weight: 13.8kg

Gross weight: 15kg



MODEL: LY250Z



Specifications

Input Voltage: AC90-260V 50/60Hz
 Light Source: 250W High Output White LED
 Control Signal: DMX 512, master-slave and sound activated or auto operation
 Control Channel: 17/20 DMX Channels USITT DMX-512
 Power Consumption: 350W
 Dimensions: 286(L)*208(W)*543(H)mm
 Packing size: 520(L)*415(W)*370(H)mm
 Net Weight: 13.50kg,
 Gross Weight: 16kg

Features

- 250W High Output White LED
- 50,000 hours lifespan and low power consumption
- Zoom angle 7° ~35° , focus function
- High light output,13300LUX@5M at White light zoom in, 950LUX@5M at White light zoom out
- Temperature protect function, when the internal Temperature is up to 40° then the fans begin to work, when the internal temperature is up to 70° and the brightness reduce half.
- Color Wheel: 9 colors +white, color fine tuning, rotation with variable direction and speed
- 1 Rotation Gobo Wheel: 8 gobos + white, wheel rotation and shake
- 1 Static Gobo Wheel: 11gobos + white, wheel rotation and shake
- Prism: 3-facet Prism, bi-directional rotatable at variable speeds
- Frost effect
- High speed strobe effect with 1-25 flashers per second
- Internal program available
- 17/20 DMX Channels USITT DMX-512
- DMX 512, master-slave and sound activated controllable or auto operation
- Colorful LCD display
- Efficient low noise fan cooling system
- PowerCon IN/OUT
- 3-pin & 5-pin XLR connectors IN/OUT

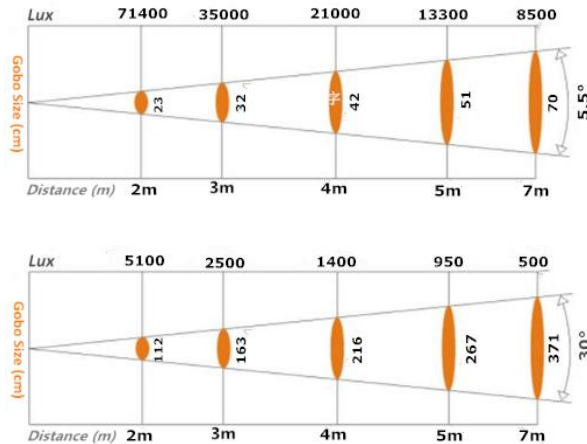
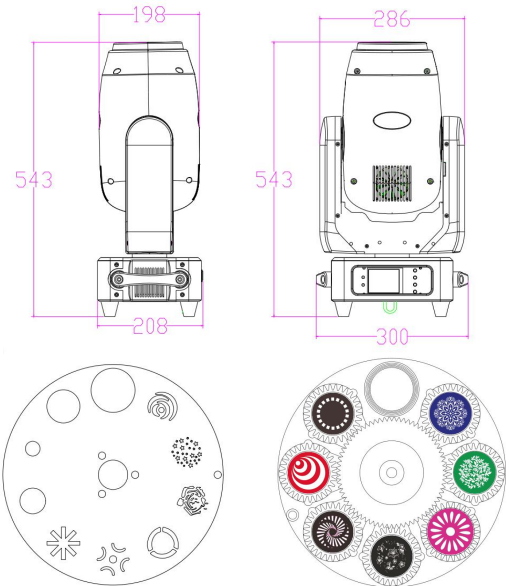

MODEL : X3 BEAM

X3 BEAM super beam is an upgraded beam lamp with high luminous efficiency, small size, fast rotation speed and precise positioning. The case shell is designed with beautiful outline; the double-layer optical lens with high light effect is used to make the beam effect full, straight and bright; the noiseless three-phase motor is used for fast response and accurate positioning; the double prism (8 linear and 8 circle prism. 48 flower prism optional) + seven color beam effect can be superimposed and flexibly used to make the whole event effect more beautiful.

Technical parameters:
 Input voltage: AC100-240V 50 / 60Hz
 Rated power: 400W
 Light source: Original Philips 8R lamp
 Color temperature: 8000K
 Bulb life: 2000 hours
 Control mode: Standard 512 DMX protocol, RDM control by 3 pin and 5 pin DMX interface
 Channel: 15 channels / 18channels
 Rotation angle: horizontal 540 ° , vertical 270 °
 (16bit precision scanning) electronic error correction
 Operation speed: horizontal 2.5 seconds, vertical 1.4 seconds
 Co wheel: 1 color wheel with 13 colors(3 glass gobo) + white, with half color effect function
 Gobo wheel: 13 fixed gobo (3 glass gobo) + white.
 Prism: 8-facet linear prism and a flower prism(i.e. 48 prism), the prism rotates and can be stacked
 Frost: soft wash effect
 Colorful wheel: when the prism is turn on, the superposition of seven color beams is beautiful
 Strobe: two piece stroboscopic 0-13 times / second, adjustable speed
 dimming: 0-100% linear dimming
 Focus: 0-100% linear focus
 Light beam angle: 0-3 ° parallel beam
 0-40 ° wash beam
 0-45 ° prism beam

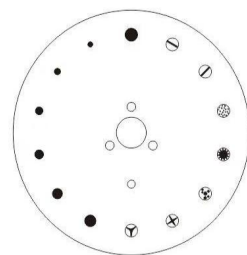
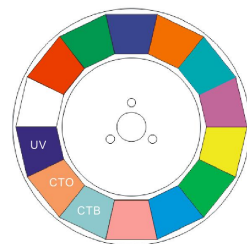

Pure Parallel Beam 0°



Frost Wash 40°



8-Facet Prism 40°



48-facet Prism+colorful wheel 45°



8 facet linear prism and 48-facet prism

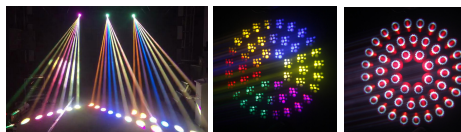

FOLDABLE CLAMP

CLAMP TURN AROUGHT



MODEL: LY200X

LY200X is an upgraded LED moving head beam light with high luminous efficiency, small size, fast rotation speed and precise positioning. The case shell is designed with beautiful outline; the double-layer optical lens with high light effect is used to make the beam effect full, straight and bright; the noiseless three-phase motor is used for fast response and accurate positioning; the 8+16 prism + seven color beam effect can be superimposed and flexibly used to make the whole event effect more beautiful.

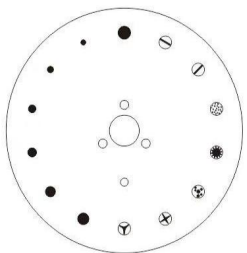
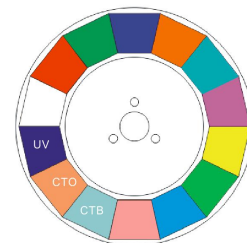
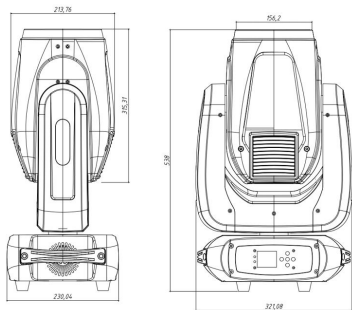

Pure Parallel Beam 0°



Frost Wash 40°



8+16 facet prism



8+16 facet prism with rainbow wheel



8+16 facet prism effect

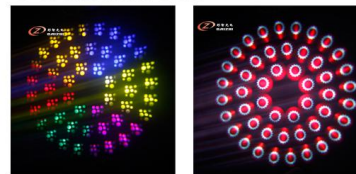

Technical parameters:

- Input voltage: AC100-240V 50 / 60Hz
- Rated power: 400W
- Light source: 200W LED
- Color temperature: 8000K
- lamp resource: 50000 hours
- Control mode: Standard 512 DMX protocol, RDM control by 3 pin and 5 pin DMX interface
- Channel: 15 channels
- Rotation angle: horizontal 540 ° , vertical 270 ° (16bit precision scanning) electronic error correction
- Operation speed: horizontal 2.5 seconds, vertical 1.4 seconds
- Co wheel: 1 color wheel with 13 colors(3 glass gobo) + white, with half color effect function
- Gobo wheel: 13 fixed gobo (3 glass gobo) + white.
- Prism: 8+16 facet prism (8 linear and 8 circle prism. 48 flower prism optional), the prism rotates and can be stacked
- Frost: soft wash effect
- Colorful wheel: when the prism is turn on, the superposition of seven color beams is beautiful
- Strobe: two piece stroboscopic 0-13 times / second, adjustable speed
- dimming: 0-100% linear dimming
- Focus: 0-100% linear focus
- Light beam angle: 0-3 ° parallel beam
0-40 ° wash beam
0-45 ° prism beam

Display mode: LCD

- USB interface: Put 5V voltage to the screen for adjust the dmX address.
- Working environment: 0-40 ° C
- Protection grade: IP20
- Cooling: adopt axial fan to strengthen ventilation and cooling
- Safety device: with temperature control overheat protection, temperature control automatic power-off protection in case of overheat system failure
- Net weight: 13.8kg
- Gross weight: 15kg

MODEL: CA250X



光束角度 2°			
光斑直径 Φ (cm)	39cm	45cm	57cm
距离 (M)	10	12	15
照度 (Lux)	165000	125000	78000

Technical Parameter

Input Voltage: AC90-260V 50/60Hz
 Light Source: 250W High Output
 Control Signal: DMX 512, master-slave and sound activated or auto operation
 Control Channel: 24 DMX Channels USITT DMX-512
 Power Consumption: 350W
 Dimensions: 286(L)*220(W)*445(H)mm
 Net Weight: 9.7kg,



Gogo wheel

Color wheel

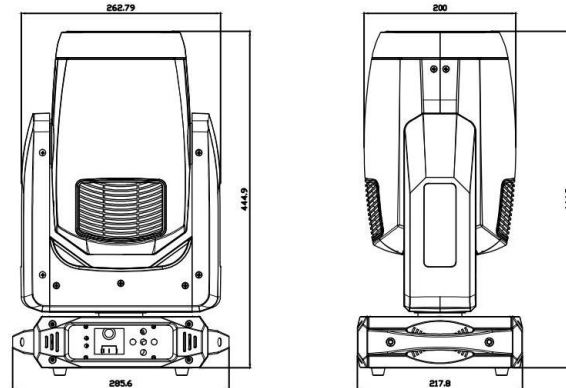

Features

- 250W High Output
- 50,000 hours lifespan and low power consumption
- angle 3° , focus function
- Temperature protect function, when the internal Temperature is up to 40° then the fans begin to work, when the internal temperature is up to 70° and the brightness reduce half.
- Color Wheel: 13 colors +white, color fine tuning, rotation with variable direction and speed
- 1 Rotation Gobo Wheel: 13 gobos + white, wheel rotation and shake
- Prism: 8-facet and 48Prism, bi-directional rotation at variable speeds
- Frost effect
- High speed strobe effect with 1-25 flashers per second
- Internal program available
- 24 DMX Channels USITT DMX-512
- DMX 512, master-slave and sound activated controllable or auto operation
- Colorful LCD display
- Efficient low noise fan cooling system
- PowerCon IN/OUT
- 3-pin XLR connectors IN/OUT

MODEL: LY150Z

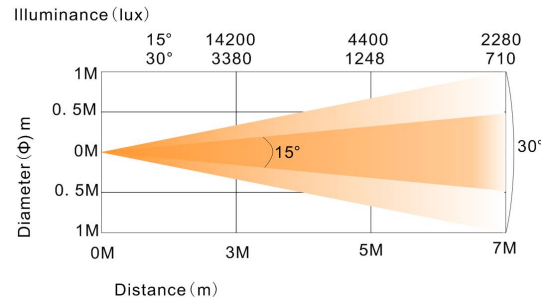

Rotating gobo

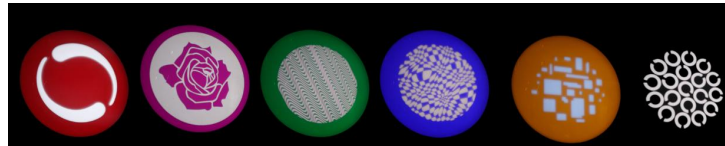

Fix gobo

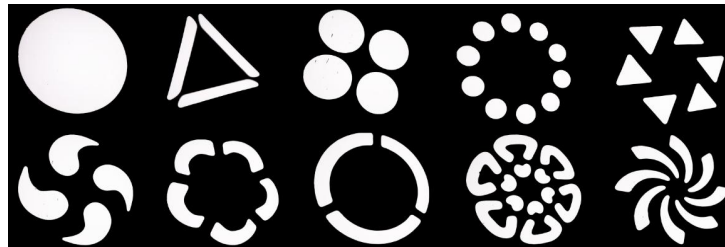

5 facet prism+rotating gobo



Specification

- Powersupply: 100 - 240 VAC, 50/60 Hz
- Power: 180W
- Light sourc: 1 piece 150W LED
- Color temperature: 6500K
- Zoom Angle: 15-30°
- Strobe: 0 ~ 20Hz
- Prism: 5 facet prism
- Color wheel: 9color+white, rainbow effect
- Rotating Gobo: 6 rotating gobo+white, bi-direction, the speed adjustable
- Fix gobo: 9 fix gobo+white, shade, rainbow effect
- Control Signal DMX512
- Channel: 20 CH
- Program: Built-in auto program
- Dimmer: linear dimmer 0-100% 16bit
- Pan/Tilt Movement: Pan 540° , Tilt270°
- Power connector: Powercon IN
- DMX connect : 3 pin DMX connector
- Display: LCD manual display
- Shell: Plastic
- Color: Black or white
- Waterproof level: IP20
- Size: 270x 210 x 400 mm
- Weight: 7.5 KG
- Cooling: Fan+cooling system
- Working temperature: 0° ~ 40° C
- Certification: CE & RoHs

MODEL: LG400



LED Projector is using high-quality 400W brightness and high power LED as the lighting source, combined with the high-definition glass optical, spot out clear and bright gobo, The rectangular logo will not bend, spot out clear and bright logo. the gobo can be changed by manual, so easy change gobo at any time. Waterproof IP65 level using in outdoor or indoor.

Technical parameter

- power supply and resource
- Power input: 100 - 240 VAC, 50 / 60 Hz
- Light source: 400w LED
- Temperature: 6500K-7000K
- Rated power: 400W
- Color rendering index: ≥ 93 Ra
- Light source life: 60000-100000 hours
- Logo: exchange Gobo
- Spot angle: 35°(50° optional)
- Focus: Manual focus
- Protection level: IP65 outdoor
- Cooling: high thermal conductivity pure aluminum forming radiator for natural heat dissipation
- Cooling system: intelligent temperature monitoring and protection, intelligent fan control and mute.
- Net Weight: 8.2kg

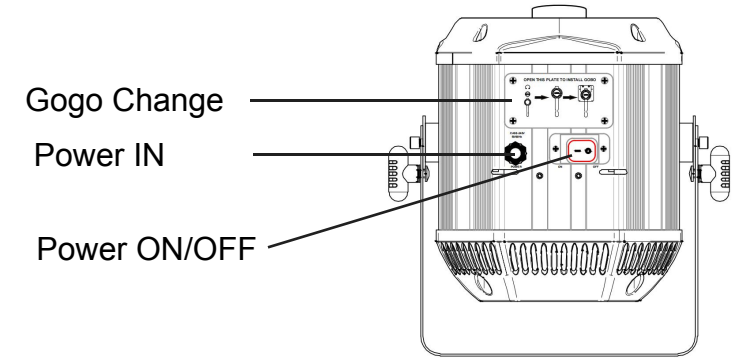
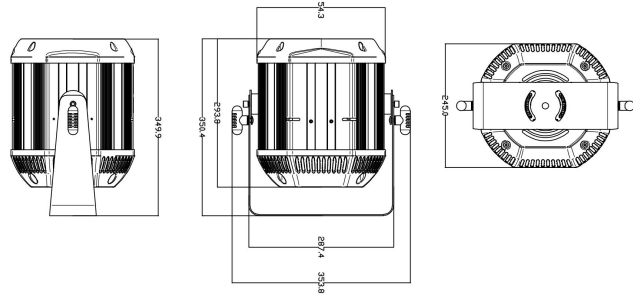

Gobo Holder:

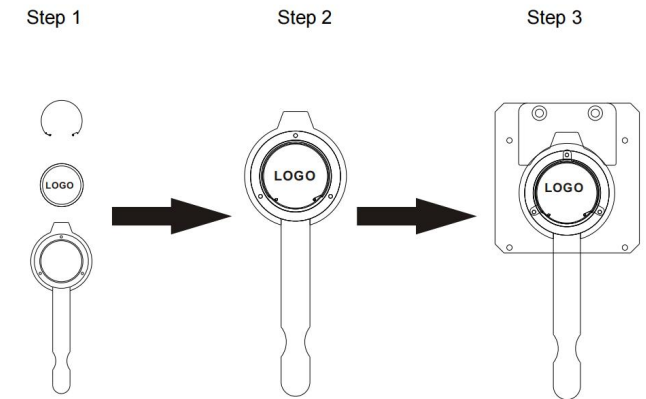

MODEL: LY100



LED MINI SPOT is a new bright LED moving head light, it composed by 1x100 Watt RGBW. and 1 color wheel, 1 fixed gobo and 1 rotating gobo, wonderful 3-facet prism, make the gobo with expecial effect, the weight is not heavy and brighter, suitable for using night club any entertainment events.

7 Roting gobo(optional)



7 fix gobo(optional)

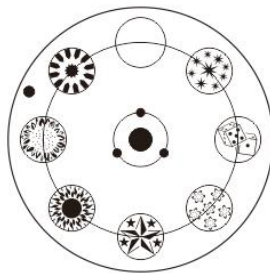

Specifications

- Voltage: AC100-240V 50-60HZ
- Light source: 1pcs of100w bright led
- Total power: 150W
- Run mode: dmx512, sound control, auto movement, master-slave
- Control channel: 14 channels
- Zoom Beam angle:25°
- Horizontal scan angle: 540 °
- Vertical scan angle: 270 °
- Color wheel: 7 colors plus rainbow effect.
- Gobo wheel1: 9 gobos with shake effect.
- Gobo wheel 2: 7 rotating gobo with interchange gobo, adjustable rotating speed.
- Prism: 3-facet Prism, rotating speed adjustable.
- Focus: electronic focus 0-100%
- Signal cable :3-pinXLR
- Display board: TFT LCD display
- Body size: 265*200*34.5mm
- N.W: 6KG



MODEL: LY400 CTO

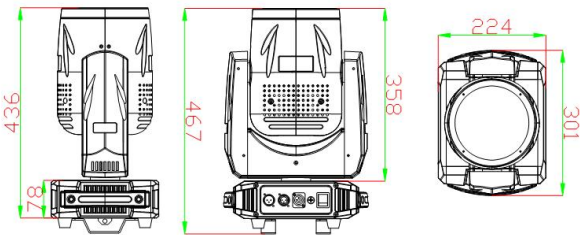

400W LED Zoom Moving Head Wash a kind of moving head with Wash and beam effects, Pan and Tilt can be arbitrarily Moving, instead of the old fixed angle surface light, the projection distance can reach 80 meters, is a new generation of full-featured surface.

Feature

- High brightness of 400W LED
- The zoom angle is 8 ° - 60 °
- 4 colors+CTO + white 6500K
- The Movement of Pan 540 ° and Tilt 270 °

Technical Parameter

- Optical system
- Light source: 1x400w LED module
- Light source life: ≥ 50000h
- Color temperature: 6500K
- CRI: ≥ 95 ultra-high object reduction color index

Electrical system

- Input voltage: AC100-240V, 50 / 60Hz
- Rated power: 450W
- Power: powercon input / output
- DMX: 3-pin DMX connector input / output

Control

- Channel mode: 8/10 channels
- Control protocol: DMX512, RDM bidirectional data transmission, remote software upgrade

- Operation mode: DMX512 , Master-slave, Auto run
- Display screen: LCD screen, can be inverted 180 ° display

Effect/Function

- Movement angle: Pan 540 ° , Tilt 270 ° 16 bit precision scanning
- Color: CTO or 4 colors + white
- Correction: automatic return correction and 16bit precision fine adjustment function, using digital wave shape correction technology, to ensure accurate positioning of Pan and Tilt, it does not shake after high-speed operation and reset
- Focusing angle: 8 ° - 60 ° linear focusing
- Dimming: 0-100% linear dimming
- Strobe: 1-25 t/s

Cooling system

- Cooling system: adopt copper tube + fan cooling structure and temperature intelligent temperature control monitoring technology, automatically adjust the cooling system, and effectively control the lamp temperature

Appearance

- Materials: high temperature resistant fireproof plastic + molded alloy material
- Working environment: - 20 °C - 40 °C
- Protection grade: IP20
- Net weight: 10kg
- Lamp size: 301x224×358mm

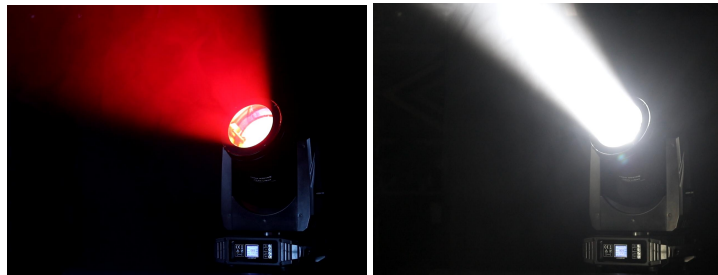

MODEL: BEE EYE 3740



BEE EYE 3740 is a new generation high-power multifunctional Moving Head Light with various effects such as zoom, beam, wash, and rotation. It uses 37x 40W LED 4in1 RGBW as the lighting source, with single point monochrome control and multiple built-in macro functions. The color is pure and saturated, with a zoom angle of 4 ° -60 °. The unique honeycomb design of the lens can rotate infinitely to bring various dreamy effects, and it is equipped with pixel LED light strip circular auxiliary light, Brilliant colors create a magical dynamic atmosphere for the lighting designer, with high brightness output, and an excellent linear dimming system; Suitable for multi-functional conference halls, theaters, bars, concerts and other entertainment events.

Specification**Electrical**

- Rated voltage: AC110-240V, 50/60Hz
- Power: 1250W
- Light source: 37pcs 40W RGBW four in one LED
- Light source lifespan: 50000 hours
- Zoom: 4 ° - 60 ° electronic zoom range

Effect:

- 3 effect modes: digital wall washing, beam, FX (kaleidoscope effect)
- Bidirectional rotation front lens
- Beam softening control
- Macro commands with pixel patterns can enhance control effects



- 0-100% linear dimming
- Speed adjustable stop/strobe effect, instantaneous light off
- Dedicated color temperature channel, 2500-8000K color temperature adjustment
- Slow strobe: 1 flash/second; High speed strobe: 25 flashes/second

Control and programming:

- Control mode: DMX512 and RDM control, supporting Ethernet interface
- Control channel: 21/35/132/146/169 channels
- Display: Color 2.8 inch display screen, Chinese and English can be switched freely
- Pan/Tilt resolution: 16 bits, dimming resolution: 16 bits
- Motion control: vector
- DMX signal connection: 3 and 5 pin XLR input and output

Structure:

- Flame retardant plastic+compression resistant alloy material
- Moving through a three-phase stepper motor:
- When accidental misoperation occurs, the horizontal and vertical can be automatically retrieved and reset.
- Horizontal: 540 ° Vertical: 270 °

Electronic:

- Optional long life battery for automatic charging
- Macro commands for preset colors and graphic effects
- The reset function can be controlled by a central controller
- Menu driven built-in self check function
- Electronic inspection of each parameter to generate parameter error alarms
- DMX Pan monitoring is distributed throughout each channel
- Automatic internal data transmission diagnostic error

MODEL: PIXEL 1940 IP



PIXEL 1940 IP is a super powerful light with IP65 level in outdoor, compact and unique honeycomb design, use 40w LED, mid-air parallel Beam, uniform Wash and spectacular built-in Graphic effect. Beam zoom from: 6-50°. It features wonderful pixel and ring effect for projection use Shape mode, Individual LED can be controller for benefit for dynamic effect, Front Lens can be rotated bi-directional and continuous effect. Very high-end and powerful light.

Specification**Electrical**

Voltage Range: 90-240 VAC, 50-60 Hz

Power consumption: 760W

LED resource: 19x40W 4in1 LED

Control

Control Channels 22/26/36/7 channels

Automatic Pan/Tilt Correction

Built-in Automatic Programs

Customizable Programs

Recall Custom Programs

Dynamic Effect**Three effects:**

1. Uniform wash,
2. mid-air parallel beam,
3. spectacular built-in graphic effect.

Individual LED control Benefit for dynamic effect

CTO: Linear controlled 2800-7000k

Pixel and Ring effect Shape mode

Lens: Front lens bi-directional continuous rotation

Wash: 0-100% fast linear Frost

Zoom: 6-60° linear Zoom

Focus: Linear Focus

Dimming: 0-100% Linear dimming

Strobe: 0-20 times per second

Move-in-Black

Pan/Tilt Range: 540°/270°

Motor: 3-phased Motor, 8 bit or 16 bit contro

Physical

Dimensions: 350X270X470 mm

Weight: 16kg

Power Connection: PowerCon in & out

Control Connection: 3-pin and 5-pin DMX input/output

Environment: IP65 outdoor

MODEL: CZ4019WASH IP



CZ4019WASH IP is a super outdoor powerful light, compact and unique honeycomb design, use 40w LED, mid-air parallel Beam, uniform Wash and spectacular built-in Graphic effect. Beam zoom from: 6-50°. It features wonderful pixel and ring effect for projection use Shape mode, Individual LED can be controller for benefit for dynamic effect, Front Lens can be rotated bi-directional and continuous effect. Very high-end and powerful light

Specification

Electrical

Voltage Range: 90-240 VAC, 50-60 Hz(auto-ranging)

Power consumption: 850W

LED resource: 19x40W 4in1 LED

Control

Control Channels: Built-in 7 channel modes 21 CH/23 CH/35 CH/78 CH/ 92 CH/97 CH/99CH

Automatic Pan/Tilt Correction

Built-in Automatic Programs

Customizable Programs

Recall Custom Programs

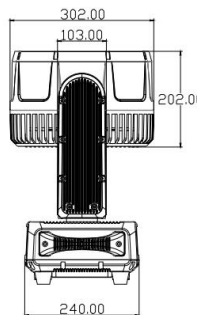
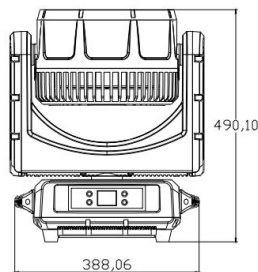

Dynamic Effect

Three effects:

1. Uniform wash,
2. mid-air parallel beam,
3. spectacular built-in graphic effect.

Individual LED control Benefit for dynamic effect

CTO:Linear controlled 2800-7000k

Pixel and Ring effect Shape mode

Lens:Front lens bi-directional continuous rotation

Wash:0-100% fast linear Frost

Zoom:6-50° linear Zoom

Focus:Linear Focus

Dimming:0-100% Linear dimming

Strobe:0-20 times per second

Move-in-Black

Pan/Tilt Range:540°/270°

Motor:3-phased Motor, 8 bit or 16 bit contro

Physical

Dimensions: 388X240X480 mm

Weight: 22kg

Power Connection:PowerCon in & out

Control Connection:3-pin and 5-pin DMX input/output

Waterproof Level: IP65 outdoor

MODEL: CZ4019WASH



CZ4019WASH is a super powerful light, compact and unique honeycomb design, use 40w LED, mid-air parallel Beam, uniform Wash and spectacular built-in Graphic effect. Beam zoom from: 6-50°. It features wonderful pixel and ring effect for projection use Shape mode, Individual LED can be controller for benefit for dynamic effect, Front Lens can be rotated bi-directional and continuous effect. Very high-end and powerful light

Specification

Electrical

Voltage Range: 90-240 VAC, 50-60 Hz(auto-ranging)
 Power consumption: 850W
 LED resource: 19x40W 4in1 LED

Control

Control Channels: 22/26/36/7 channels
 Automatic Pan/Tilt Correction
 Built-in Automatic Programs
 Customizable Programs
 Recall Custom Programs

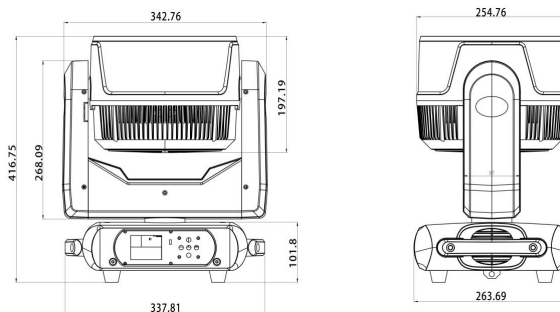

Dynamic Effect

Three effects:

1. Uniform wash,
2. mid-air parallel beam,
3. spectacular built-in graphic effect.

Individual LED control Benefit for dynamic effect
 CTO:Linear controlled 2800-7000k
 Pixel and Ring effect Shape mode
 Lens:Front lens bi-directional continuous rotation
 Wash:0-100% fast linear Frost
 Zoom:6-50° linear Zoom
 Focus:Linear Focus
 Dimming:0-100% Linear dimming
 Strobe:0-20 times per second
 Move-in-Black
 Pan/Tilt Range:540°/270°
 Motor:3-phased Motor, 8 bit or 16 bit contro

Physical

Dimensions: 350X270X470 mm
 Weight: 16kg
 Power Connection:PowerCon in & out
 Control Connection:3-pin and 5-pin DMX input/output
 Environment IP20, dry location

MODEL: CJ10W



Technical parameter

- Rated voltage: AC110-220V
- Shaking head laser +LED dye light
- Rated frequency: 50 ~ 60Hz
- Rated power: 300W
- Laser color: RGB full color
- Laser power: RGB 10W
- Laser light source: R3w/638nm G3w/525nm B4w/447nm
- Laser pattern: 256 laser animation pattern
- Modulation signal: TTL modulation (analog modulation)
- Scanning system: galvanometer scan 30KPPS
- Scanning Angle: plus or minus 20 degrees
- Stepper motor: two phase 57 motor 2
- Horizontal: 540 degrees Vertical: 270 degrees
- LED dyeing configuration: 9 20W four-in-one high brightness LED lamp beads
- Control mode: DMX512, voice control, self-walking, computer ILDA interface, cable Art-Net,
- Control channels: 30 DMX512 control channels
- DMX special effects: single pattern mode, can be broken pen, stroboscopic, rotating, moving, tumbling, subgraph, gradually drawing, color change, change the size and other functions.
- Function: Pangolin QSFB3/FB4 or fire Phoenix laser software control.
- ilda control uses an automatic electronic transfer switch with scanning system error protection and laser light protection.
- Notice for use: The ambient temperature is controlled at 0~35 ° C, and the dry and dust-less environment can reduce the laser power attenuation and extend the life of the lamp
- Suitable place: disco bar, bar, nightclub, concert, advertising promotion, etc
- Cooling system: fan forced cooling

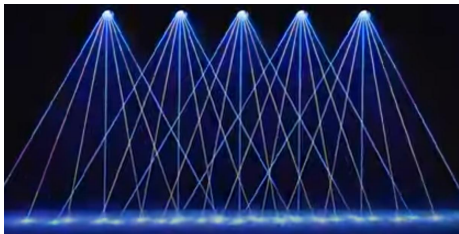

MODEL: PIXEL 760 IP

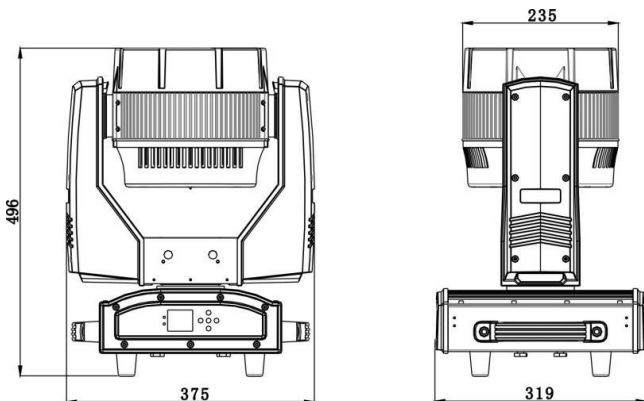

PIXEL 760 IP is a super powerful light with IP65 level in outdoor, compact and unique honeycomb design, use 60w 4in1 LED RGBW, uniform Wash and spectacular built-in Graphic effect. Beam zoom from: 6-40°. It features wonderful pixel and ring effect for projection, Individual LED can be controller for benefit for dynamic effect, the powerful light good for using in outdoor event.

Specification➤ **Electrical**

- Voltage Range: 90-240 VAC, 50-60 Hz
- Power consumption: 500W
- LED resource: 7x60W Osram 4in1 LED RGBW
- Color Temperature: 2500K-8000K
- Lifetime: 50,000-100,000 hours

➤ **Control**

- Control Channels: 17 channels
- Automatic Pan/Tilt Correction
- Built-in Automatic Programs
- Customizable Programs
- control mode: DMX512, RDM, Auto Run, Master/slave

Function:

- Uniform wash,
 - spectacular built-in graphic effect.
 - Individual LED control Benefit for dynamic effect
 - Pixel and Ring effect
 - Zoom:6-40° linear Zoom
 - Dimming:0-100% Linear dimming
 - Strobe:0-25 t/s, speed can be ajustabled
 - Display: LCD dipsplay, support Chinese& English
 - Pan/Tilt Range:540°/270°
 - Motor:3-phased Motor, 8 bit or 16 bit contro
- **Physical**
- Dimensions: 375X320X496 mm
 - Weight:17kg
 - Power Connection: 1.5M cable with IP65 Power connector
 - Control Connection:1.5M cable with IP65 dmx connector
 - Environment: IP65 outdoor and indoor

MODEL: Q6S MINI BEE EYE



Technical parameter

- Input voltage: AC90 - 240V, 50/60hz
- Power: 350W@220V

Optical system

- Lighting resource: OSRAM 40W LED RGBW 4in1
- Quantity LED: 7pcs x LEDs, each LED can be controlled
- Lifetime: more than 50000 hours
- zoom range: 4-60 ° , 16800lux@5m @Minimum angle
- Color temperature: 2500-9000k can be adjusted linearly
- Color range: Color RGBW (red green blue white) linear color mixing adjustment

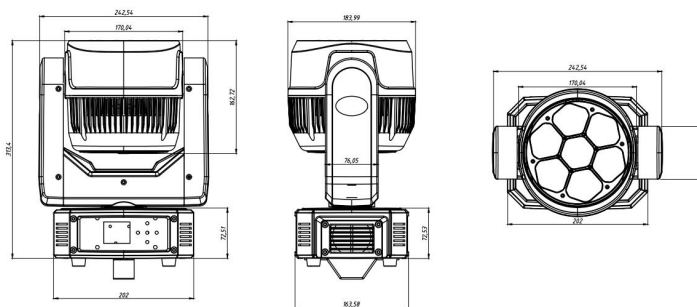

Function effect

- It has the functions of wash, beam, graphic effect, matrix, etc
- There are 31 kinds of front layer graphics and 3 kinds of back layer (background) graphics. Each graphic can be changed in color, strobe and brightness.
- The front layer can be used for fast / slow gradient, fade and density animation effects, and the back layer can be used for static effects
- The front Lens can be rotated fast / slowly in two directions, with classic effects such as vortex, kaleidoscope, waist, etc
- 4 0-100% linear dimming modes,
- 2 color switching modes (RGBW / CMY)
- Slowest strobe speed: 1 time / s, fastest speed: 25 times / s, with instantaneous dark field function
- Pan movement: 540 ° electronic error correction, accurate positioning
- Tilt movement: 230 ° electronic error correction, accurate positioning
- LCD display

Control model

5 control modes:

1. 3pin DMX512 signal input / output
2. DMX signal
3. manual control mode
4. automatic test mode
5. sound active mode

5 channel control modes(Clay Paky)

1. Standard mode 21ch
2. built in shape mode 35ch
3. expansion mode RGBW 42ch
4. expansion mode 49ch
5. full mode 63ch

Appearance

Seamless lens design, aspheric lens structure

Black shell: new ABS fireproof engineering plastic material

Weight: 5.5kg

MODEL: LM1915



LM1915 WASH is a high-power zooming moving head wash Light, which combines with the LED array. The electronic zoom angle is 5-60° , a variety of circle control effects, which can be used for special scene background effects, and the response is quick. This product is mostly used in professional theaters, bars, concerts and other entertainment Place

Specifications

Light Source: 19 x 15W Osram RGBW(4 in 1)
led array
Zoom Range: 5° ~ 60°
Luminous Flux: 5780lm

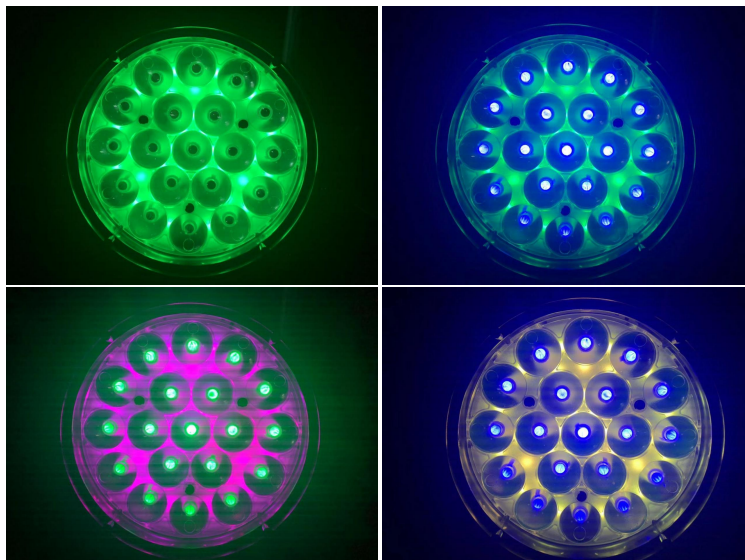

Control

DMX Channel: 14/25 Channels
Control Modes: DMX, wireless control (Optional)
Firmware Upgrade: Update via DMX link

Pan/Tilt

Pan/Tilt: 540° / 265°
Pan/Tilt Resolution: 16 bit

Construction

Display: LCD Display
Data In/Out: 3-pin & 5-pin XLR
Power In/Out: PowerCon in/out
Protection Rating: IP20

Features

Motorized liner zoom system, zoom range: 10° ~63°
Outstanding color macro effect
0~100% smooth dimming
Variable strobe effects
Fast, quiet, flicker free operation

Electrical and Physical

Power Voltage: AC100~240V, 50/60Hz
Power Consumption: 300W
Dimension: 332x165x335mm
Net Weight:11kg

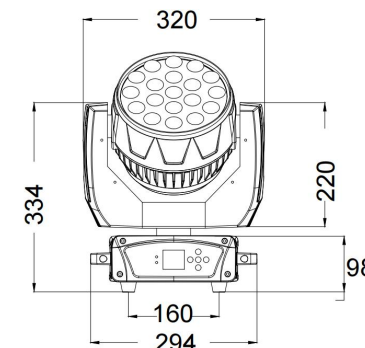

MODEL: PIXEL 640 ZOOM

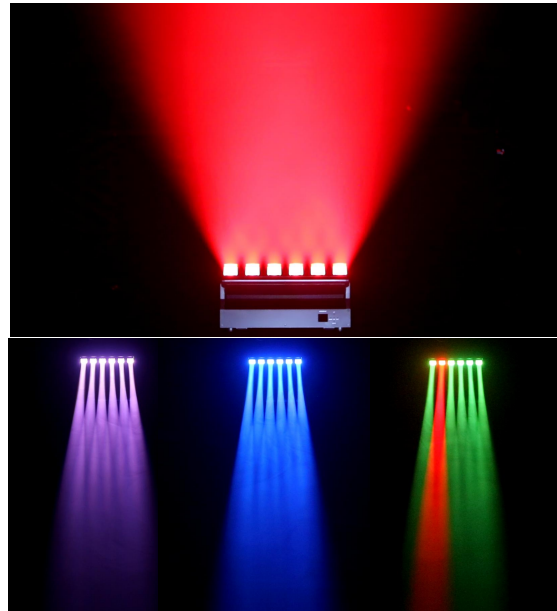

Connecting



Size

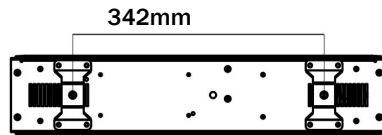
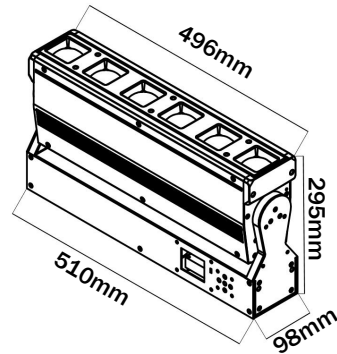

Backview



Hunging



PIXCEL MOVING BAR is an upgraded beam light with high power efficiency. Tilt movement, pixel effect, with zoom 3.5 ° - 35 ° . composed by beam and wash effect. The fixtures can be connecting in long moving bar light, good for using in big show .

Technical parameters:

- Led quantity: 6x40w Osram LED 4in1 (RGBW)
- Driving current: 2.5A
- Maximum power: 400W
- Power supply: 100v-240v, 50-60Hz
- Color temperature: 2800k-8500k
- Lamp life: 50000 hours
- Zoom: 3.5 ° - 35 °
- Control mode: DMX512, master-slave operation,
- Control channel: 18ch / 32ch
- Support RDM function, and upgrade function of DMX software
- Optional network function support: artnet, klingnet, sacn, network protocol
- Tilt movement: 270 °
- Focusing: high mute motor, precise focusing, no jitter of spot
- Display: color LCD display, Chinese and English display, reverse display
- Strobe: 1-20t/s
- Dimming: 0-100% linear dimmer (16bit)
- Working environment temperature: 0 ° C-45 ° C
- High efficiency cooling system, whole process temperature monitoring, over temperature automatic adjustment protection, no lamp bead damage risk
- Intelligent speed regulation fan, real-time display temperature
- Weight: 9.15kg

MODEL: PIXEL 1240 ZOOM



PIXCEL MOVING BAR is an upgraded beam light with high power efficiency. Tilt movement, pixel effect, with zoom 3.5° - 35° . composed by beam and wash effect. The fixtures can be connecting in long moving bar light, good for using in big show .

Technical parameters:

- Led quantity: 12x40w Osram LED 4in1 (RGBW)
- Driving current: 2.5A
- Maximum power: 500W
- Power supply: 100v-240v, 50-60Hz
- Color temperature: 2800k-8500k
- Lamp life: 50000 hours
- Zoom: 3.5° - 35°
- Control mode: DMX512, master-slave operation,
- Control channel: 16ch / 60ch
- Support RDM function, and upgrade function of DMX software
- Optional network function support: artnet, klingnet, sacn, network protocol
- Tilt movement: 270°
- Focusing: high mute motor, precise focusing, no jitter of spot
- Display: color LCD display, Chinese and English display, reverse display
- Strobe: 1-20t/s
- Dimming: 0-100% linear dimmer (16bit)
- Working environment temperature: 0° C- 45° C
- High efficiency cooling system, whole process temperature monitoring, over temperature automatic adjustment protection, no lamp bead damage risk
- Intelligent speed regulation fan, real-time display temperature
- Weight: 9.15kg

MODEL: PIXEL 1060 ZOOM IP

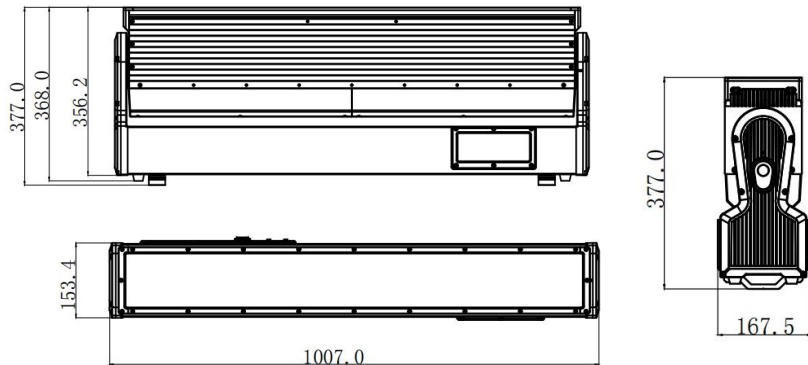

PIXEL 1060 ZOOM MOVING BAR is an upgraded outdoor light with high power efficiency, Feature at pixel power beam and wash, aslo backgroup pixel line effect. Tilt movement, pixel effect, with zoom $3.5^{\circ} - 35^{\circ}$, Waterproof IP level IP65 good for using in big show .

Technical parameters:

- Led quantity: 10x60w LED 4in1 (RGBW), 140 pcs 5050 5in1 led
- Maximum power: 700W
- Power supply: 100v-240v, 50-60Hz
- Color temperature: 2800k-8500k
- Lamp life: 50000 hours
- Zoom: $3.5^{\circ} - 35^{\circ}$
- Control mode: DMX512, master-slave operation,
- Control channel: CH26、CH36、CH56、CH66、CH166
- Support RDM function, and upgrade function of DMX software
- Optional network function support: artnet, klingnet, sacn, network protocol
- Tilt movement: 270°
- Focusing: high mute motor, precise focusing, no jitter of spot
- Display: color LCD display, Chinese and English display, reverse display
- Strobe: 1-20t/s
- Dimming: 0-100% linear dimmer (16bit)
- Working environment temperature: $0^{\circ} \text{C} - 45^{\circ} \text{C}$
- High efficiency cooling system, whole process temperature monitoring, over temperature automatic adjustment protection, no lamp bead damage risk
- Intelligent speed regulation fan, real-time display temperature
- Waterproof Level: IP65
- Weight: 9.15kg

MODEL NO.: LB660



Photometrics	
Light Source	6 x 60W 4 in 1 LEDs RGBW
Beam Angle	2°
Pan/Tilt Angle	120°/180°
Key Features	
Color Mixing	RGBW+color mix
Strobe	0 ~ 20Hz
Dimming	linear dimming no flick
Control	
Protocol	DMX, RDM
DMX Channels	16CH / 45ch
Built-in Programs	Yes
Display	TFT menu with four-button navigation
Power	
Mains	100 - 240 VAC, 50/60 Hz
Consumption	400W

I/O	
Power connections	Powercon In/Out
Data connections	XLR In/Out for DMX,
Housing	
Material	plastic and Iron
Finish	Matte black
IP rating	IP20
Thermal	
Cooling	Variable speed fans
Ambient operating temps	-20° ~ 40°C
Physical	
Dimensions	1200x 12 x 240 mm
Weight	20 KG
Misc / Options	
Power Cord	Powercon
Floor mounting bracket	include
Flight case	Optional

MODEL: COLORSFOT-M



LED Moving Soft Light are equipped with new intelligent dimming technology, which can be directly used with DMX512 to completely replace traditional colors lights. The light emitting wash cover bigger range area , the color is uniform, and there is no shadow. It is a modern revolutionary lamp, which is widely used in TV studios, conference, Church, multi-function halls, museums, galleries, stages and other places.

Control

Dimming: 0-100% 16bit
Control protocol: DMX512
DMX channel: 8/10CH, 2/4CH
Tilt Movement: 0-270 degrees

Connecting way

Power connection: powercon self-locking safety plug input and output
Signal connection: three core signal input and output

appearance

Display: LCD four key display
Protection level: IP20

Dissipate heat

Cooling: high thermal conductivity pure aluminum forming radiator for natural heat dissipation
Intelligent cooling system: intelligent temperature monitoring and protection, intelligent fan control and mute.
Operating temperature: - 0 ° ~ 40 ° C

Specifications

Size: 32x21x21mm
Weight: 6.5kg

MODEL: COLORSFOT



Technical parameter

power supply and resource
Power input: 100 - 240 VAC, 50 / 60 Hz
Light source: 2X200w COB RGBW, warm white optional
Rated power: 400W
Color rendering index: ≥ 93 Ra
Light source life: 50000 hours
Pan Beam angle: 80 °
Tilt Beam angle: 45 °

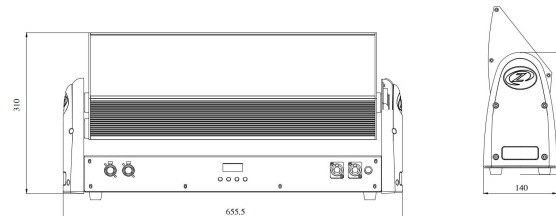
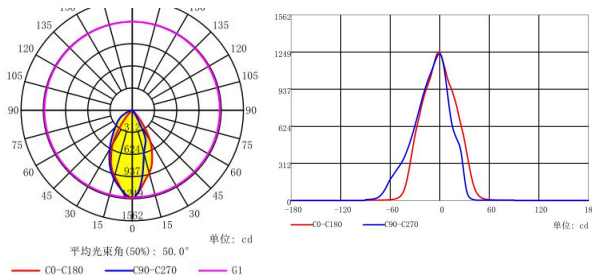

MODEL: LWF300



LED Profile Light is equipped with new intelligent dimming technology, using monochrome 4000k warm white as the light source, IP65 waterproof level and directly used with DMX512, and with the bracket can be used as a tracer lamp. Four brake discs (optional aperture and pattern clip) are included to create multiple effect functions. It is a major breakthrough in the stage lighting industry and a revolutionary modern lighting in outdoor.

Product characteristics:

1. Mute temperature regulation: According to the bulb temperature, real-time fan speed regulation, so that the temperature and fan speed achieve a balance, it is for reduce the noise generated by the fan.
2. 16-bit dimming: Compared with 8-bit dimming, the light changes more gently and delicately.
3. Lighting changes can be adjusted, and the corresponding gradient effect can be adjusted according to the specific needs.

Product parameters:

Power input: AC90-250V 50/60Hz

Lamp source: imported ultra-high brightness 300W COB warm white

Color temperature: 4000K

Chromogenic index: > 93Ra

Dimming Curve: Four Dimming Curves (Linear/Nonlinear/Sine/Logarithm)

Control mode: manual or DMX 512

Optical system: 19 degrees (26 degrees/36 degrees optional)

Channel: 2CH

Intelligent heat dissipation system: temperature intelligent monitoring, protection, intelligent fan control, silence.

High Quality Optical System

Waterproof Level: IP65

Size: 280x350x680mm

Net weight: 12 kg

MODEL: LW200



LED Profile Light is equipped with new intelligent dimming technology, using monochrome warm white (cold white) as the light source, directly used with DMX512, and with the bracket can be used as a tracer lamp. Four brake discs (optional aperture and pattern clip) are included to create multiple effect functions. It is a major breakthrough in the stage lighting industry and a revolutionary modern lighting.

Illuminance at Distance

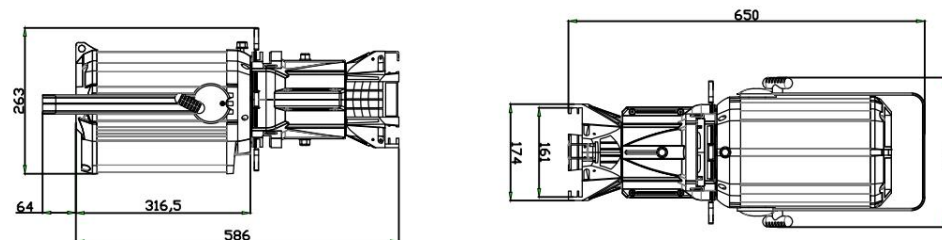
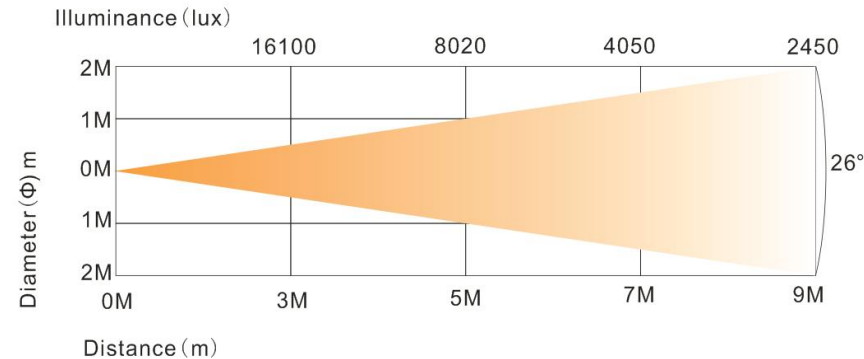

Product characteristics:

1. Mute temperature regulation: According to the bulb temperature, real-time fan speed regulation, so that the temperature and fan speed achieve a balance, it is for reduce the noise generated by the fan.
2. 16-bit dimming: Compared with 8-bit dimming, the light changes more gently and delicately.
3. Lighting changes can be adjusted, and the corresponding gradient effect can be adjusted according to the specific needs.

Product parameters:

Power input: AC90-250V 50/60Hz
 Lamp source: imported ultra-high brightness 200W COB white or 4in1 RGBW
 Color temperature: 4000K
 Chromogenic index: > 93Ra
 Dimming Curve: Four Dimming Curves (Linear/Nonlinear/Sine/Logarithm)
 Control mode: manual or DMX 512
 Optical system: 19 degrees (26 degrees/36 degrees optional)
 Channel: 2CH
 Intelligent heat dissipation system: temperature intelligent monitoring, protection, intelligent fan control, silence.
 High Quality Optical System
 Small size and light weight
 Size: 280x350x680mm
 Net weight: 10.5 kg

MODEL: LW200F

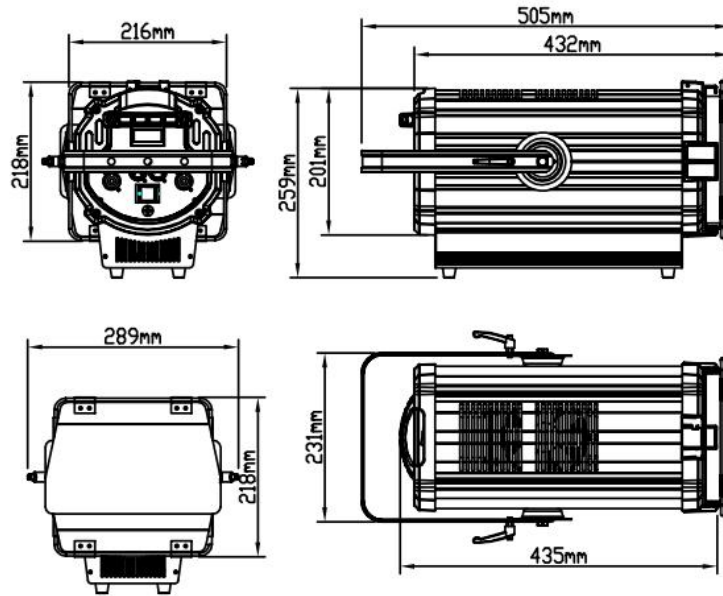

LED Fresnel Light applied new-type intelligent lighting technology, made by a warm white 200W LED(or cold light), controlled by DMX512 protocol, zoom in and out function, linear dimmer soft light with no flicker, which can meet the demand of stage,theater,church,fashion show.

**Product characteristics:**

- 1: Dissipate heat according the cooling system include over heat protection system, extend the using time.
- 2:16 bit light adjustment,its more soft compared to 8 bit light adjustment.

Power supply Input: AC100~240 V/50-60Hz

Power consumption: 200W,

LED: 1xWhite 200W 3200K

Color Rendering Index(CRI) Ra>90

Zoom angle: 15°-50° (manual zoom optional)

DMX Channel: 2 Channel

Power connector: powercon input/output

DMX connector: DMX 3pin or 5pin

Cooling: silence fan with cooling system

Body in aluminium

IP20 protection rating

Measurement: L47xW23xH22m (barndoor: 18cm, with handle:36 cm)

Weight: 7kg

MODEL: LW600



LED Soft Light (Hung Style) is a high-power soft light flat light with two-color temperature of 3200k-5600k. Different color temperatures can be selected in this range to meet the needs of different event. Soft dimming, no flicker, no glare, environmental protection and energy saving, long service life, no noise, no need to change the light bulb, color rendering index of restored object is greater than 95, DMX512 control protocol, this product is mostly used in professional conference hall, studio, multi-function hall, professional viewfinder and other places.

technical parameter
Light Resource/Power

Power Supply	100 - 240 VAC, 50/60 Hz
Power	300W
LED Resource	Bright 600pcs 5050 LED warm white 300 LED, white 300 LED
Color Temperature	3200K-5600K
Lifetime	50,000 Hours
CRI	≥95

Control

Dimmer	Linear dimmer 0-100% 16bit
Control protocol	DMX512
DMXChannel	2CH、5CH
Function	single machine setting dimming, color temperature dimmer from 3200K to 5600K, saving preset data, can be connected with multiple light, master-slave operation

Connection Mode

Power connection	Connecting powercon cable
DMX connection	3 pin DMX connector in/out, (5pin connector optional)

Appearance

Display	LED 4 key display
Protection Level	IP33

Dissipate Heat

Cooling	natural heat dissipation of high heat conduction pure aluminum shaped radiator
Working Temperature	-0° ~ 40°C

Specifications

Size	530x300x90mm
N.W	7.5KG

MODEL: HL6012 WASH

Price: 265 USD



COLOR WASH IP is a high-power outdoor LED color wash light. It adopt 60 piece of 15W 4in1 RGBW LED as the light source. The optical part uses high-efficiency optical lens. The light mixes evenly after passing through the lens. The light efficiency is higher than that of ordinary lenses. The lamp has beautiful appearance and novel structure. It uses a new type of waterproof fan to dissipate heat, which greatly improves the life and performance of LED. The waterproof grade reaches IP65, which is suitable for outdoor stage dyeing, architectural decoration and exhibition hall, gymnasium, landmark building etc.



- **Technical parameter**
- Power input: AC100-240V 50/60Hz
- Power: 720W
- Light Source: Imported 60 Ultra-bright 15W 4IN1 LED RGBW color(6IN1 optional)
- 16.7 million Mix-color.
- Beam angle: 25° (15, 45 ° optional)
- Channel mode: 4/5/9CH
- Dimming Curve: 4 linear dimming curve from 0-100%
- Signal Input/Output: 3pin or 5pin DMX connector
- Power Input/Output: Neutrik PowerCON TRUE1 Socket
- Cooling system: three silent waterproof fans
- Ambient temperature: - 20 to 40 degrees centigrade
- Maximum lamp body temperature: 70 C
- Waterproof coefficient: IP65
- Body size: 50cm x 26cm x 30cm(LxWxH)
- N.W: 10kg

External control mode

- DMX512 console control, master-slave control, self-propelled mode
- Built-in program
- Various Gradient and Pulse Effects
- Various stroboscopic effects: variable speed (from slow to fast), mixing (stroboscopic + background, stroboscopic + gradient)...
- Self-programming: Powerful, practical and interesting programming functions. It can be programmed without console to realize gradient, jump, stroboscopic and so on.

Modelo: HL1812

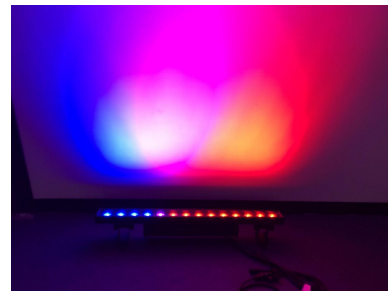
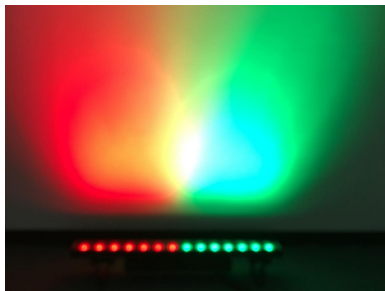

LED Bar Light adopt 18 piece 12w 4in1 COB LED, each color of LED can be controlled, built-in running programs and with color washer effect, good for using in background in stage, night club, Bar, Casino Project and other entertainment place.

**Technical parameters:**

- Power input: AC100-240V 50/60Hz
- Power: 216W
- Light source: 18X12w 4in1 LED
- Optical angle: 30degree
- Channel: 9ch / 27ch / 82ch / 72ch
- Signal Input/Output: Waterproof Triple 3pin connector
- Power Input/Output: Waterproof Power connector
- Control mode: DMX512, Auto run built-in program, master-slave mode
- Control panel: digital display menu control
- Effect: Built-in multi-variable effect, high-power LED single led and color can be controller.
- Water Level: IP65
- Product size: 100 x 10 x 20(cm)
- Net weight: 10KG
- Suitable places: indoor and outdoor stage event,

MODEL: LS3000



3000 LED STROBE is the perfect blend of a traditional strobe and cutting-edge LED technology. it is not only s strobe, but also a creative tool that incorporates backlight illumination with RGB-controlled LEDs, pointing into the reflector. it delivers stunning eye cady looks similar to the Aura(backlight) array.

- brightest LED-based strobe on the market.
- unique RGB-controlled Aura backlight for stunning eye cany looks.
- channels same as Matin Atomic 3000 LED



Feacture

- Classic reflector look
- Aura backlight(RGB) into reflector
- dimmable house-light function at reduced brightness and power consumption
- LED and Xenon mode available via menu and DMX control channel.
- 4 button menu and LCD display for quick and easy setting adjustment.
- Cleaver rigging and bracket solution.
- 4 Channels DMX mode ad Atomic 3000(easy replacement)
- 14 Channels Extened DMX mode incl. Aura control and internal FX marco

Technical Specifications

- light source: 228x3w white LEDs (strobe)
64x0.6w RGB LEDs(backlight) array
- minimum LED lifetime: 50000 hours
- Resolution: 8 bits per color plus 8-bit dimming
- Control system: DMX
- DMX channels: 3/4/14 channels(same as Matin Atomic)
- Setting: Control panel with backlit monochrome display
- N.W: 7kg
- G.W: 8.5kg
- Packing size: 50x24x34cm(1 pcs/carton)
52x50x39cm (2 pcs/carton)
- Flightcase: 80x60x69cm (6pcs in 1 case)

MODEL: PIXEL 3000 IP



LED PIXEL MOVING STROBE LIGHT is powerful color wash and strobe effect light, it is made by 128 pixel, each pixel can be controlled. there are building in running effect. it is good for using in any event for backgroup decoration and strobe effect.

Technical Specifications

- LED light source: 256 piece 3030 white 3W led, 864piece of 5050 RGB-0.5 w LED
- LED pixel: 3x 16 pixel x 2 area RGB, 32 pixel white in middle

Movement

- Resolution: 8-16 degrees
- Error correction function: Yes
- Tilt selection (angle): 185 °
- Channel mode: CH09, CH23, CH135, CH151, CH343
- Display screen: LCD liquid crystal display screen
- Control mode: Standard DMX-512, RDM
- RDM: Bidirectional communication
- Cooling system: temperature control, overheating protection

Effect

- Dimming: 0-100% linear dimming
- Strobe frequency: 20 Hz
- Built in effects: LED built-in rich macro function effects

Connect

- Signal connection: IP65 DMX signal 5-PIN or 3-PIN input/output
- Power connection: powercon input/output

Operating standards

- Rated voltage: 100-240V AC/50-60Hz
- Rated power: 600W

Installation operation

- Standing: Machine feet
- Hanging: Quick lock
- Safety rope: hanging buckle point

Size&Weight

- Body Size: 544x169x367mm
- Net weight: 10 kg

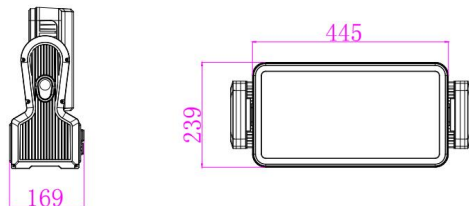
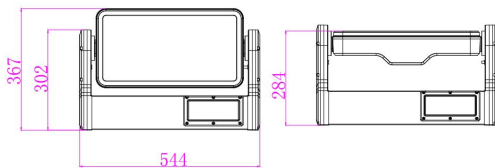

MODEL: PIXEL 1000 IP

LED STROBE BAR LIGHT is powerful color wash and strobe effect light, it is made by 70 pixel, each pixel can be controlled. there are building in running effect. it is good for using in any event for backgroup decoration and strobe effect.

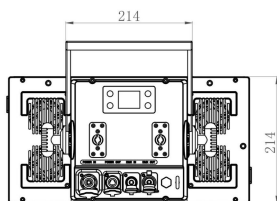
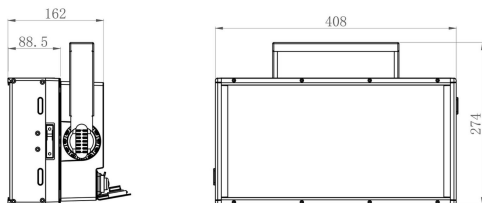
**Technical Specifications**

- Input voltage: AC100-240V 50/60Hz
- Rated power: 1000W
- Lamp: 200 *3W CW + 800 *0.5W RGB
- Beam angle: 68°
- Spot angle: 114°
- Display board control: sound active mode/auto run mode/master-slave mode
- Control protocol: DMX512, RDM
- Dimmer mode: 5
- Dimmer cure: 4
- Channel Mode: 15/50/158 CH
- Effectiveness: white 3x10 pixel, RGB 4x10 pixel
- Dimming: Linear and non-linear dimming 0-100%
- Stroboscopic: 0-30Hz
- Waterproof level: IP65
- Fixture connection: 3pin connector input/output, electrical powercon input and output.
- Cooling system: air cooling
- Weight: 11.5kg

MODEL: PIXEL 1080 IP II

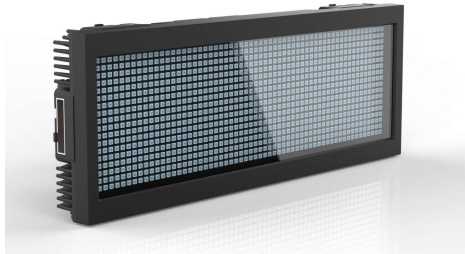

LED STROBE BAR LIGHT is powerful color wash and strobe effect light, it is made by 120 pixel, each pixel can be controlled. there are building in running effect. it is good for using in any event for backgroup decoration and strobe effect.

Technical Specifications

- Input voltage: AC100-240V 50/60Hz
- Rated power: 800W
- Lamp: 1080W 0.8W RGBW 4in1 led
- Display board control: sound active mode/auto run mode/master-slave mode
- Control protocol: DMX512, RDM
- Channel Mode: 4 Ch,11CH, 131CH, 171CH,480CH
- Effectiveness: 120 pixel, each pannel can be controlled independently.
- Dimming: Linear and non-linear dimming 0-100%
- Stroboscopic: 0-30Hz
- Projection angle: 150 °
- Size: L1000xW100xH150 (mm)
- Weight: 6kg
- Color: Black
- Waterproof mirror: cast aluminium
- Lamp connection: 3pin signal line input/output, electrical input.
- Cooling system: air cooling

MODEL: STROBE 630 IP

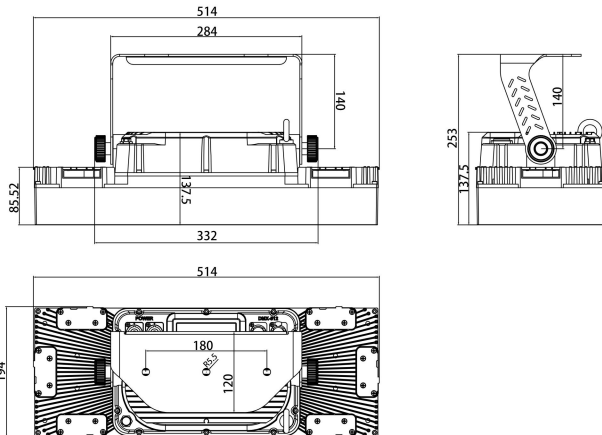

Technical Specifications

- Input voltage: AC100-240V 50/60Hz
- Rated power: 400W
- Lamp: 30 x 10W 3535LED, 600 x 0.5W RGB 3in1 led
- Display board control: sound active mode/auto run mode/master-slave mode
- Control protocol: DMX512, RDM
- Channel Mode: 13/16/23AC/25/19/23BC/31/35/51/120/128CH
- Effectiveness: Built-in kinds of colorful Backgroup and beam effect.
- Dimming: Linear and non-linear dimming 0-100%
- Stroboscopic: 0-30Hz
- Beam angle: 3 °
- Spot angle: 150 °
- Size: L507xW186xH260 (mm)
- Weight: 8kg
- Color: Black
- Waterproof mirror: cast aluminium
- Lamp connection: 3pin signal line input/output, electrical input.
- Cooling system: air cooling

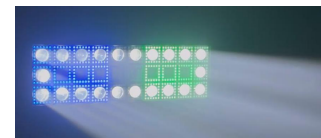

MODEL: PIXEL 784 IP

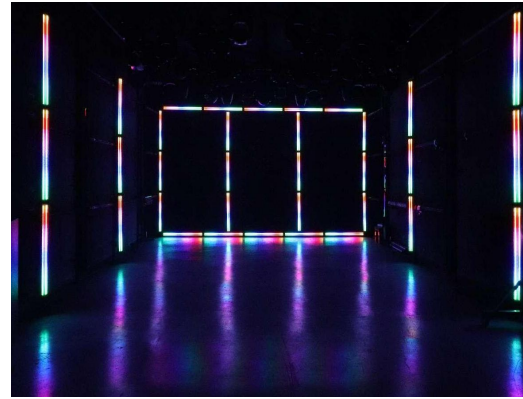
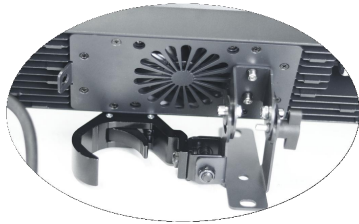

Connecting

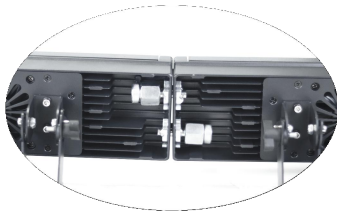

LED PIXEL BAR LIGHT is powerful color wash and strobe effect light, it is made by 2X16 pixel RGB and 1X16 pixel white, each pixel can be controlled. there are building in running effect. IP65 waterproof level good for using in any outdoor event for backgroup decoration and strobe effect.

Technical Specifications

- Input voltage: AC100-240V 50/60Hz
- Rated power: 600W
- Lamp: 672 pcs 3in1 RGB leds, 112 pcs white LED
- Display board control: voice control mode/self-propelled mode/master-slave mode
- Control protocol: DMX512, RDM
- Channel Mode: 7/15/21/39/112/17/33/68/65/117/70CH
- Effectiveness: 32+16 pixel, each pannel can be controlled independently. body can be connected for long bar
- Dimming: Linear and non-linear dimming 0-100%
- Strobe: 0-30Hz
- Projection angle: 120 °
- Size: L1000xW95xH200 (mm)
- Weight: 7.8 kg
- Color: Black
- Waterproof mirror: cast aluminium
- Fixture connection: 3pin dmx cable input/output, power input/output.

MODEL: PIXEL 1080 IP



DUAL FOLD CLAMPS



Pixel 1080 IP LED BAR LIGHT is powerful color wash and strobe effect light, it is made by 120 pixel, each pixel can be controlled. there are building in running effect. it is good for using in any event for backgroup decoration and strobe effect.

Technical Specifications

- Input voltage: AC100-240V 50/60Hz
- Rated power: 800W
- Lamp: 1080W 2W RGBW 4in1 led
- Display board control: sound active mode/auto run mode/master-slave mode
- Control protocol: DMX512, RDM
- Channel Mode: 7/12/52/127/85/165CH
- Effectiveness: 120 pixel, each panel can be controlled independently.
- Dimming: Linear and non-linear dimming 0-100%
- Fog effect: linear fog from 0-100%
- Stroboscopic: 0-30Hz
- Projection angle: 150 °
- Size: L1000xW110xH150 (mm)
- Net Weight: 9 kg
- Color: Black
- Waterproof mirror: cast aluminium
- Lamp connection: 3pin signal line input/output, 16A Power connector in/out.
- Cooling system: air cooling

MODEL: HL300Z

300W Zoom Par IP65 adopts one 300W LED, 3200K warm white or 5600k white. Low power consumption, no flicker, service life of 60000-100000 hours, low power consumption and super brightness. 3 ° - 45 ° electric zoom angle, wide projection range and long range. The waterproof Level IP65, which is widely used for outdoor stage and night scene event.

Technical parameter

Power system

Input power supply: AC 90v-245v / 50-60Hz

Rated power: 300W

LED source: 1x 300W cob led warm white 3200K / 5600k

LED life: 50000-100000 hours

Control

Control mode: DMX512, Auto Run, master / slave

RMD protocol: two-way data transmission, software upgrade, and address code setting through the console.

Channel: 2, 3CH

Optical system and effect

Dimming: linear or nonlinear dimming 0-100%

Stroboscopic: 0-20hz

Zoom angle: 3 ° - 45 °

Connection mode

Power connection: Waterproof powercon connecting input and output

Signal connection: Waterproof 3-pin DMX signal input and output

Appearance

Display: LCD display

Material: Alloy Illuminum

Color: black or white

Protection level: IP65

Dissipate heat

Cooling: the chassis convection + waterproof fan heat dissipation, built-in temperature control and measurement function, intelligent control of LED output power

Operating temperature: - 0 ° ~ 40 ° C

Specifications

Size: 394x235x305 (mm)

Weight: 8kg

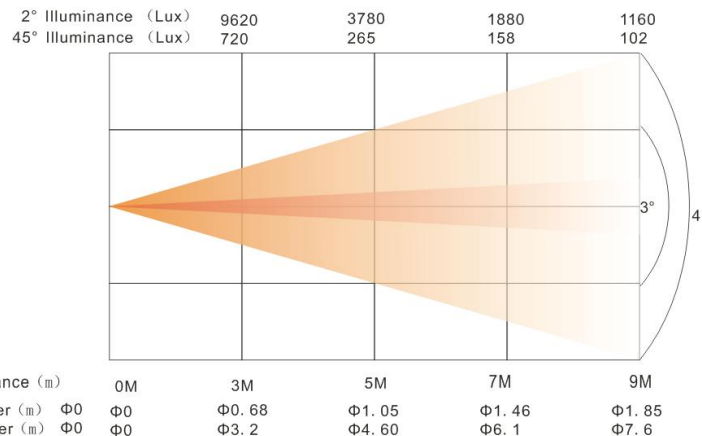

MODEL: ZOOM PAR 740 IP



ZOOM Par 740 adopts 7x40W 4in1 LED, base color by Red, Green, Blue, White. 167,000 Colors. Low power consumption, no flicker, service life of 50000-100000 hours, low power consumption and super brightness. 2° - 45° electric zoom angle, wide projection range and long range. The waterproof Level IP65, which is widely used for outdoor stage and night scene event.

Technical parameter

Power system

Input power supply: AC 90v-245v / 50-60Hz

Rated power: 300W

LED source: 7x 40W 4in1 led

LED life: 50000-100000 hours

2° Illuminance (Lux)	RGBW	31000	10200	5500	3450
		R	3160	1280	610
G		7680	3040	1585	890
B		12230	4780	2440	1470
W		9510	3710	1770	1150
45° Illuminance (Lux)	RGBW	1880	680	380	220
		R	230	85	55
G		495	195	108	68
B		781	310	165	95
W		610	230	133	75

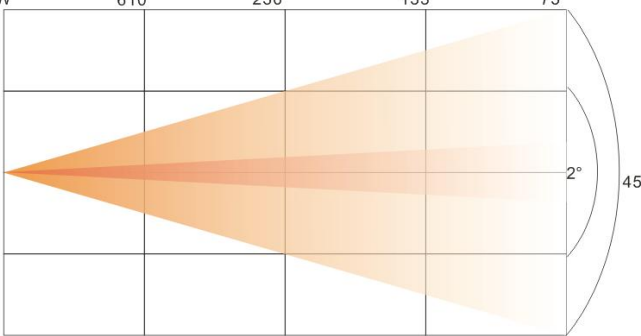
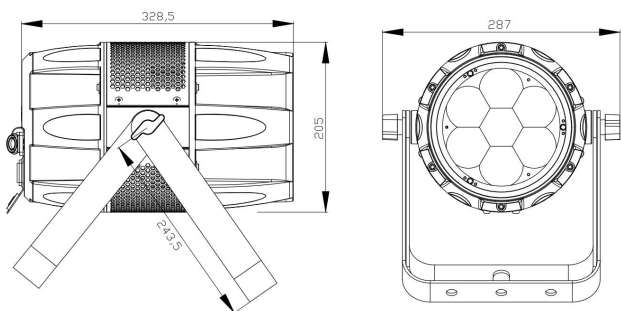

Spot Distance (m)	0M	3M	5M	7M	9M
2° diameter (m)	Φ0	Φ0.3	Φ0.48	Φ0.75	Φ0.9
45° diameter (m)	Φ0	Φ1.95	Φ3	Φ4.7	Φ5.8

Control

Control mode: DMX512, Auto Run, master / slave

RMD protocol: two-way data transmission, software upgrade, and address code setting through the console.

Channel: 5, 9CH

Optical system and effect

Dimming: linear or nonlinear dimming 0-100%

Stroboscopic: 0-20hz

Zoom angle: 2° - 45°

Connection mode

Power connection: Waterproof powercon connecting input and output

Signal connection: Waterproof 3-pin DMX signal input and output

Appearance

Display: LCD Display

Material: Alloy Aluminum

Color: black or white

Protection level: IP65

Dissipate heat

Cooling: the chassis convection + waterproof fan heat dissipation, built-in temperature control and measurement function, intelligent control of LED output power

Operating temperature: - 0° ~ 40° C

Specifications

Size: 328.5x287x305 (mm)

Weight: 7.8 kg

MODEL: LP18200



LP18200 is multi-function par light in door events, adopts 18x15W 4in1 RGBW LED and 1 x 200W warm white. feature at colorful back ground and face light for stage, no flicker, long lifetime for 50000-100000 hours, low power consumption and super brightness. good for using multi-function events.

Technical parameter

Power system

Input power supply: AC 90v-245v / 50-60Hz

Rated power: 500W

LED source: 18x 20W 4in1 led and 1x200W Warm white COB

LED life: 50000-100000 hours

Control

Control mode: DMX512, Auto Run, master / slave

RMD protocol: two-way data transmission, software upgrade, and address code setting through the console.

Channel: 6, 9CH

Optical system and effect

Dimming: linear or nonlinear dimming 0-100%

Stroboscopic: 0-20hz

Connection mode

Power connection: powercon connecting input and output

Signal connection: 3-pin DMX signal input and output

Appearance

Display: LCD Display

Material: Alloy Aluminum

Color: black or white

Dissipate heat

Cooling: the chassis convection + waterproof fan heat dissipation, built-in temperature control and measurement function, intelligent control of LED output power

Operating temperature: - 0 ° ~ 40 ° C

Specifications

Size:300*255*240 (mm)

Weight: 7.5 kg

MODEL: CP3020

CP3020 LED PAR LIGHT adopts 30x20W high power 4in1 LED, base color by Red, Green, Blue, White. 167,000 Colors. Low power consumption, no flicker, service life of 50000-100000 hours, low power consumption and super brightness. which is widely used for indoor stage and night scene event.

Technical parameter**Power system**

Input power supply: AC 90v-245v / 50-60Hz

Rated power: 600W

LED source: 30x 20W 4in1 led

LED life: 50000-100000 hours

Control

Control mode: DMX512, Auto Run, master / slave

RMD protocol: two-way data transmission, software upgrade, and address code setting through the console.

Channel: 4/8CH

Optical system and effect

Dimming: linear or nonlinear dimming 0-100%

Stroboscopic: 0-20hz

Connection mode

Power connection: powercon connecting input and output

Signal connection: 3-pin DMX signal input and output

Appearance

Display: LCD Display

Material: Alloy Aluminum

Color: black or white

Dissipate heat

Cooling: the chassis convection + waterproof fan heat dissipation, built-in temperature control and measurement function, intelligent control of LED output power

Operating temperature: - 0 ° ~ 40 ° C

Specifications

Size:300*255*240 (mm)

Weight: 4.5 kg

MODEL: LP1915Z



LP1915Z ZOOM Par adopts 19x15W 4in1 LED, base color by Red, Green, Blue, White. 167,000 Colors. Low power consumption, no flicker, service life of 50000-100000 hours, low power consumption and super brightness. 10° - 55 ° electric zoom angle, wide projection range and long range, which is widely used for indoor stage and night scene event.

Technical parameter**Power system**

Input power supply: AC 90v-245v / 50-60Hz

Rated power:250W

LED source: 19x 15W 4in1 led

LED life: 50000-100000 hours

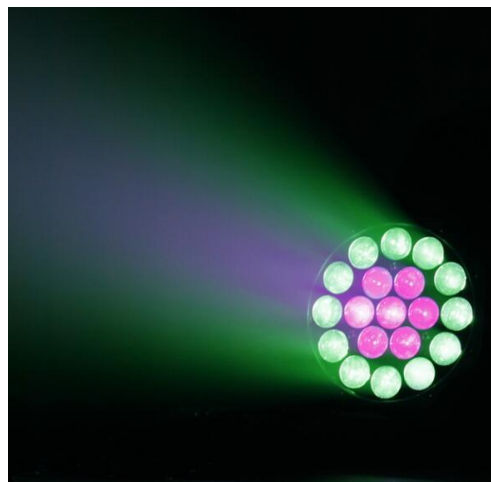
**Control**

Control mode: DMX512, Auto Run, master / slave

RMD protocol: two-way data transmission, software upgrade, and address code setting through the console.

Channel: 6, 9CH

Optical system and effect

Dimming: linear or nonlinear dimming 0-100%

Stroboscopic: 0-20hz

Zoom angle: 10° - 55°

Connection mode

Power connection: powercon connecting input and output

Signal connection: 3-pin DMX signal input and output

Appearance

Display: LCD Display

Material: Alloy Aluminum

Color: black or white

Dissipate heat

Cooling: the chassis convection + waterproof fan heat dissipation, built-in temperature control and measurement function, intelligent control of LED output power

Operating temperature: - 0 ° ~ 40 ° C

Specifications

Size:300*255*240 (mm)

Weight: 7.5 kg

MODEL: HL2410P

**Features**

LED PAR LIGHT IP65 adopt advance LED technology, save electronic, It can be put out RGBW and mix color about 16 million colors, the color changing and circle effect is very smoothly, it is suitable for using in outdoor decorating, such like wedding, Concert, decorating building, outdoor stage back group and tree etc.

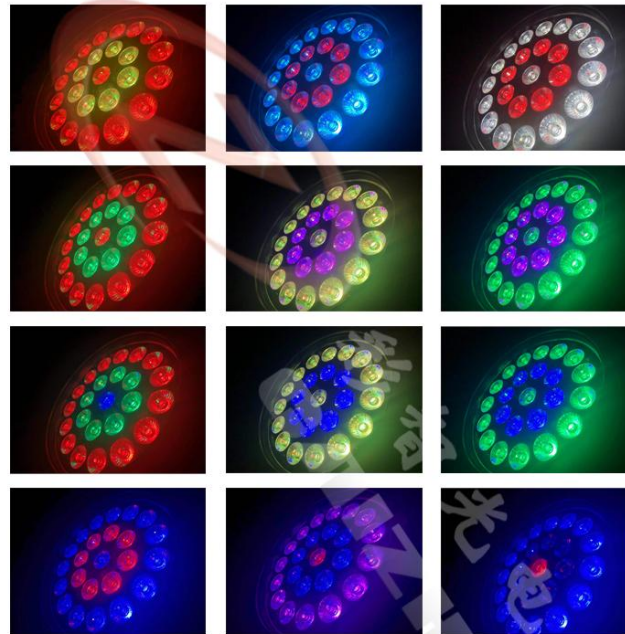
**Light Source**

LED Qty: 24x 12W bright LED(R14,G14,B14,W12)
 Drive current: 500mA
 Color Range: 16.7million additive RGBW colors
 Full saturation control
 Electrical
 Input Voltage: AC100-240V 50/60Hz
 Power: 240W

Control

Manual control: Auto run mode and Master/slave
 Protocol: DMX512
 Personality: 10CH/5CH/18CH

Effects

7 Colors jumping change, 7 color gradual change and 7 color pulse change with circle effect.
 3 circle effects, each color of circle can be controlled, the speed can be adjustable

Optical System

Dimmer: linear or non linear dimmer 0-100%
 Strobe: 0-20Hz
 Optics: 25°(/40°optional)

Physical:

Dimension: L34xW25xH23(cm)
 Weight: 6.2 kg
 Housing: Die-casting aluminum
 Color: Black or white
 Lens Plate: Tempered glass
 Fixture connection: 3 pin data in/out, power in/out

Certification and Safety

Certification: CE
 Environment: Dry/Damp/Wet Location IP65.
 Operation Temperature: -40°C-70°C

LP18-4in1



LP54-3



LP425



LP200

LED PAR LIGHT have many kind of lighting resource, 18x10W 4in1 LED, 54x3W LED RGBW, 4x50W Cree LED warm white and 1x200w COB LED. All of them can using in stage for color wash, the warm white color spot front of even, make the stage more bright, the colorful par light, is for make the event more exciting and nice.

Specification

wash Input voltage: AC100-240V 50/60Hz

LED QTY: 18x10W 4in1 LED (LP18-4IN1)

54 x 3W LED (R12, G18,B18, W6) (LP54-3)

4X25w led 3200K,(LP425), each led can be controller

1x200W COB 3200K (LP200)

power: 162-200W

Color temperature: 3200K - 6500K

lens angle: 25 °(LP18-4IN1, LP54-3),

15 °(LP425)

45 ° (LP200)

strobe: 0-20t/s

Channels: 4/8CH (LP18-4IN1, LP54-3)

8CH(LP425)

1+2CH(LP200)

Dimming: linear and non linear dimming 0-100% , no flicker.

Control mode: DMX 512, auto run, master/slave, sound active.

DMX and power: 3 pin connector with 1M XLR and power connector with 1M cable.

Display: LED digital manual display

Shoot distance: 15M

shell: Alluminum Alloy

size: L25xW23xH26(CM)

weight: 4.5KG

MODEL: LF5403



MODEL: LF2410

**Features**

FLAT PAR 5403 adopt advance LED technology, save electronic, the base color with RGBW and mix color about 16 million colors, the color changing effect is very smoothly, the power cable and DMX cable can be connected between them. it has silence fan, It is suitable for using in indoor decorating events, such like wedding, church, Concert, decorating building, stage back group and tree etc.

**SPECIFICATION****Light Source**

LED Qty: 54 x 3W bright LED(R14,G14,B14,W12)
24 x 10W 4in LED RGBW

Drive current: 600mA

Color Range: 16.7million additive RGBW colors

Full saturation control

Electrical

Input Voltage: AC100-240V 50/60Hz

Power: 180W/240W

Control

Manual control: Auto run mode and Master/slave

Protocol: DMX512

Personality: 4/8CH

Optical System

Dimmer: linear or non linear dimmer 0-100%

Strobe: 0-20Hz

Optics: 25° (15/40/60° optional)

Physical:

Dimensions: 216x177x270(mm)

Weight: 8.6 kg

Housing: Die-casting aluminum

Color: Black or white

Fixture connection: 1meter cable 3 pin data in/out, power cable in/out

Certification and Safety

Certification: CE, Rohs

Environment: Dry, IP33.

Operation Temperature: -40°C-65°C

MODEL: HL54-3

**Features**

LED PAR 5403 IP is adopt advance LED technology, save electronic, the base color with RGBW and mix color about 16 million colors, the color changing effect is very smoothly, the power cable and DMX cable can be connected between them. No fan, IP65 waterproof level, It is suitable for using in indoor or outdoor decorating events, such like wedding, church, Concert, decorating building, stage back group and tree etc.

MODEL: HL450

**SPECIFICATION****Light Source**

LED Qty: 54 x 3W bright LED(R14,G14,B14,W12)
4x50W bright LED Warm White

Drive current: 550mA

Color Range: 16.7million additive RGBW colors

Full saturation control

Electrical

Input Voltage: AC100-240V 50/60Hz

Power: 170W/200W

Control

Manual control: Auto run mode and Master/slave

Protocol: DMX512

Personality: 4/8CH

Optical System

Dimmer: linear or non linear dimmer 0-100%

Strobe: 0-20Hz

Optics: 25° (15/40/60° optional)

Physical:

Dimensions: 216x177x270(mm)

Weight: 6 kg

Housing: Die-casting aluminum

Color: Black or white

Fixture connection: 1meter cable3 pin data in/out, power cable in/out

Certification and Safety

Certification: CE, Rohs

Environment: outdoor IP65.

Operation Temperature: -40° C-65° C

MODEL: LBP-6



Feature

- 1, The battery can last for 6-8 hours when all LED on after full charge , and can last for more than 9-13 hours on auto running mode. Up to 20 Hours with red color diode on, about 12 hours if other single color on. Results will vary based on brightness of LED
- 2, it is suggested to charge the battery for at least 4 hours, which will extend the life span of the battery.

Features:

1. With Built-in 2.4G Wireless DMX 512 Receiver (DA-WDMX-PCB)
2. Rechargeable Powered: 12V 12000mah
3. Perfect Match up with 2.4 Wireless DMX 512 Transmitter (DA-WDMX-LCD)
4. Wifi mode by phone controlled (down load "LED Wifi" software)
5. Lux: 6,500 @ 1m
6. Switching Power Supply
7. Two DMX channels : 6/10
8. Electronic Linear Dimmer: 0-100%
9. High speed Electronic Strobe: 0-20/S
- 10.3-Pin DMX in and DMX out
11. Daisy Chain Power in and Power out
12. Led Digital Display Menu
13. Double Bracket
14. Body Color: Black or White Selectable

Technical parameters

- Input voltage: AC100V-250V/50-60HZ
- Power: 120W
- Light Source: 6*20W High Brightness LED Beads (6 in 1)
- Color: 16.7 million color changes
- Waterproof grade: IP65
- Life of light source: 50000 hours
- Lens angle: 25 °
- Control: DMX512, master-slave control, self-walking, 2.4G wireless DMX512
- Infrared remote control,WiFi mobile phone APP control (Apple and Android supported)
- Battery: imported 18650 lithium battery *12 3 strings 4 and 4*2200=8800 capacity
- Charging and discharging can reach more than 500 times
- Charging time: full charge in5 hours
- Discharge time: RGBWAUV is fully bright for 5 hours and monochromatic for 35hours.
- Self-propelled mode 10 hours

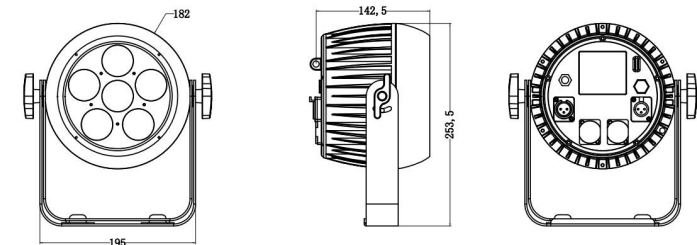

MODEL: SQ618



Feature

1, The battery can last for 6-8 hours when all LED on after full charge , and can last for more than 9-13 hours on auto running mode. Up to 20 Hours with red color diode on, about 12 hours if other single color on. Results will vary based on brightness of LED

2, it is suggested to charge the battery for at least 4 hours, which will extend the life span of the battery.

Features:

1. With Built-in 2.4G Wireless DMX 512 Receiver (DA-WDMX-PCB)
2. Rechargeable Powered: 12V 12000mah
3. Perfect Match up with 2.4 Wireless DMX 512 Transmitter (DA-WDMX-LCD)
4. Wifi mode by phone controlled (down load "LED Wifi" software)
5. Lux: 6,500 @ 1m
6. Switching Power Supply
7. Two DMX channels : 6/10
8. Electronic Linear Dimmer: 0-100%
9. High speed Electronic Strobe: 0-20/S
- 10.3-Pin DMX in and DMX out
11. Daisy Chain Power in and Power out
12. Led Digital Display Menu
13. Double Bracket
14. Body Color: Black or White Selectable

Technical parameters

- Input voltage: AC100V-250V/50-60HZ
- Power: 108W
- Light Source: 6*18W High Brightness LED Beads (6 in 1)
- Color: 16.7 million color changes
- Waterproof grade: IP65
- Life of light source: 50000 hours
- Lens angle: 15 40
- Control: DMX512, master-slave control, self-walking, 2.4G wireless DMX512
- Infrared remote control,WiFi mobile phone APP control (Apple and Android supported)
- Battery: imported 18650 lithium battery *12 3 strings 4 and 4*2200=8800 capacity
- Charging and discharging can reach more than 500 times
- Charging time: full charge in5 hours
- Discharge time: RGBWAUV is fully bright for 5 hours and monochromatic for 35hours.
- Self-propelled mode 10 hours

MODEL WP1218

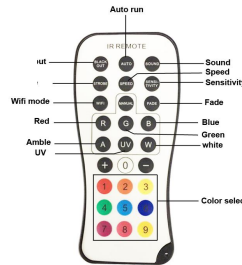

BACKSIDE INSTRUCTION

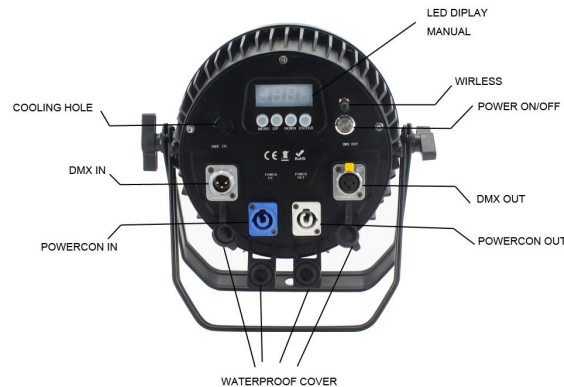

Feature

1, The battery can last for 6-8 hours when all LED on after full charge , and can last for more than 9-13 hours on auto running mode. Up to 20 Hours with red color diode on, about 12 hours if other single color on. Results will vary based on brightness of LED

2, it is suggested to charge the battery for at least 4 hours, which will extend the life span of the battery.

Features:

1. With Built-in 2.4G Wireless DMX 512 Receiver (DA-WDMX-PCB)
2. Rechargeable Powered: 12V 12000mah
3. Perfect Match up with 2.4 Wireless DMX 512 Transmitter (DA-WDMX-LCD)
4. Wifi mode by phone controlled (down load "LED Wifi" software)
5. Lux: 12,500 @ 1m
6. Switching Power Supply
7. Two DMX channels : 6/10
8. Electronic Linear Dimmer: 0-100%
9. High speed Electronic Strobe: 0-20/S
10. 3-Pin DMX in and DMX out
11. Daisy Chain Power in and Power out
12. Led Digital Display Menu
13. Double Bracket
14. Body Color: Black or White Selectable

Technical parameters

- Power supply: AC100V-240V
- Frequency: 50 Hz-60 Hz
- Power consumption: 110W
- Light source: 12x6in1 LED RGBWA+UV
- Lamp life: 6-10 ten thousand hrs
- LED angle: 30(±5) degree
- Color: 16.7 million kinds of color change
- Control channels: 6/10 chs
- Battery power& wireless DMX
- Wireless DMX512 protocol
- Built-in 2.4G wireless receiver/transmitter for wireless DMX operation
- Control mode: DMX512, master/slave, auto, sound active, wireless DMX
- Automatic model (by function button): color change, color strobe, color dimmer, and color gradual change/color jump change
- Operation menu: 4 digit digital LCD display
- Packing size: 20mm*24mm*200mm
- N.W: 5.5kg



MODEL: WBP418



Feature

1, The battery can last for 6-8 hours when all LED on after full charge , and can last for more than 9-13 hours on auto running mode. Up to 20 Hours with red color diode on, about 12 hours if other single color on. Results will vary based on brightness of LED

2, it is suggested to charge the battery for at least 4 hours, which will extend the life span of the battery.

Features:

1. With Built-in 2.4G Wireless DMX 512 Receiver (DA-WDMX-PCB)
2. Rechargeable Powered: 12V 12000mah
3. Perfect Match up with 2.4 Wireless DMX 512 Transmitter (DA-WDMX-LCD)
4. Wifi mode by phone controlled (down load "LED Wifi" software)
5. Lux: 6,500 @ 1m
6. Switching Power Supply
7. Two DMX channels : 6/10
8. Electronic Linear Dimmer: 0-100%
9. High speed Electronic Strobe: 0-20/S
10. 3-Pin DMX in and DMX out
11. Daisy Chain Power in and Power out
12. Led Digital Display Menu
13. One Bracket
14. Body Color: Black or White Selectable

Technical parameters

- Power supply: AC100V-240V
- Frequency: 50 Hz-60 Hz
- Power consumption: 72W
- Light source: 4x6in1 LED RGBWA+UV
- Lamp life: 6-10 ten thousand hrs
- LED angle: 30(±5) degree
- Color: 16.7 million kinds of color change
- Control channels: 6/10 chs
- Battery power& wireless DMX
- Wireless DMX512 protocol
- Built-in 2.4G wireless receiver/transmitter for wireless DMX operation
- Control mode: DMX512, master/slave, auto, sound active, wireless DMX
- Automatic model (by function button): color change, color strobe, color dimmer, and color gradual change/color jump change
- Operation menu: 4 digit digital LCD display
- Packing size: 185mm*185mm*200mm
- N.W: 2.5kg

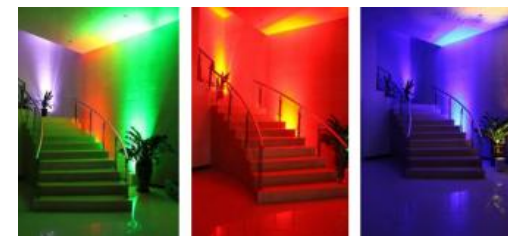

MODEL: WB418



Feature

1, The battery can last for 6-8 hours when all LED on after full charge , and can last for more than 9-13 hours on auto running mode. Up to 20 Hours with red color diode on, about 12 hours if other single color on. Results will vary based on brightness of LED

2, it is suggested to charge the battery for at least 4 hours, which will extend the life span of the battery.

Features:

1. With Built-in 2.4G Wireless DMX 512 Receiver (DA-WDMX-PCB)
2. Rechargeable Powered: 12V 12000mah
3. Perfect Match up with 2.4 Wireless DMX 512 Transmitter (DA-WDMX-LCD)
4. Wifi mode by phone controlled (down load "LED Wifi" software)
5. Lux: 6,500 @ 1m
6. Switching Power Supply
7. Two DMX channels : 6/10
8. Electronic Linear Dimmer: 0-100%
9. High speed Electronic Strobe: 0-20/S
10. 3-Pin DMX in and DMX out
11. Daisy Chain Power in and Power out
12. Led Digital Display Menu
13. Double Bracket
14. Body Color: Black or White Selectable

Technical parameters

- Power supply: AC100V-240V
- Frequency: 50 Hz-60 Hz
- Power consumption: 144W
- Light source: 4x6in1 LED RGBWA+UV
- (6 piece led optional)
- Lamp life: 6-10 ten thousand hrs
- LED angle: 30(±5) degree
- Color: 16.7 million kinds of color change
- Control channels: 6/10 chs
- Battery power& wireless DMX
- Wireless DMX512 protocol
- Built-in 2.4G wireless receiver/transmitter for wireless DMX operation
- Control mode: DMX512, master/slave, auto, sound active, wireless DMX
- Automatic model (by function button): color change, color strobe, color dimmer, and color gradual change/color jump change
- Operation menu: 4 digit digital LCD display
- Packing size: 138mm*138mm*200mm
- N.W: 2.5kg

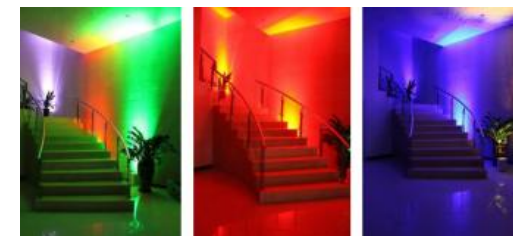

MODEL: J10W-A



- Laser: All-solid-state semiconductor laser
- Input voltage: AC110v-240V50/60Hz
- Total power: 10W
- Input voltage: 85-240V50/60Hz
- Output power: 500W
- Laser Type: All-solid-state semiconductor laser
- Scanning speed: +/-30
- Scanner : 25kpps
- galvanometer angle: 60o standard Original scanning unit and scanning drive circuit, the maximum speed of 40000PPS.
- SD Effect: There is a SD card in the back panel of the laser machine, by which you can edit the programs by yourself ,there are more than 128beam animation programs in SD card,some copied from ishow software

MODEL: J10W-B



- Service life: 10000 hours
- Divergence angle: <1.2mrad
- Projection distance: 50meters
- Projection pattern area: 60 square pattern size can be adjusted
- Cooling method: air-cooled
- Control mode: voice-activated/automatic DMX512 control/master-slave synchronization, ILDA interface (IsoW software can be connected and imported pangolin, Phoenix software)
- DMX control function: Twelve-channel control, black-field function, computer interface, compatible with ILDA standard computer laser show. Software control: ILDA's full signal is converted by electronic switch
- Full-color animation laser, using high-speed galvanometer scanning speed, pattern with pen break, strobe, rotation, roll, move, stretch, zoom, draw, speed, color and other effects, with a pattern size adjustment function, built-in 128 Beams and animations can be used for beam animation, laser advertising, and laser projection.
- Optical Table, Optical Holder, Laser Dedicated Lens, Laser-specific Laser Lamp Thermostat, Laser-Specific Aluminum Alloy Chassis (Features: Good Heat Dissipating Function and Corrosion Resistance)
- Product size / net weight: 35*30*23/10kgs

MODEL: L6500



Power supply: AC90-240V,50-60Hz±10%

Rated power: max 400W

Laser power: RGB2W*6pcs

Laser modulated signal: analog or TTL modulation

Type of laser: imported semiconductor solid-state laser

Beam diameter at the aperture : <6mm

Beam divergence:<1.3mrad

Laser wavelength: red 638±5nm, green 520±5nm, blue 450±5nm

Scanning system: 15KPPS speed scanning *6pcs

Control mode: DMX512 signal control /self-walk/voice control/master-slave

Suitable places: show , dacing hall, club, Bar and other enterntainment venues

Working environment: indoor (-10~40 degrees)

Packing : carton case

MODEL: J5-1W RGB



Power supply: AC90-240V,50-60Hz±10%

Rated power: max 200W

Laser power: RGB1W*5pcs

LED serouce: 6 pcs x 5W cree LED, beam angle 3°-5°

Laser modulated signal: analog or TTL modulation

Type of laser: imported semiconductor solid-state laser

Beam diameter at the aperture :<6mm

Beam divergence:<1.3mm

Laser wavelength: red 638±5nm, green 520±5nm, blue 450±5nm

Pan Movement: 540°

Tilt Movement : 270°

Channels: 14CH/39CH

Control mode: DMX512 signal control /self-walk/voice control/master-slave

Suitable places: show , dacing hall, club, Bar and other enterntainment events.

Body: Size: 66x18.5x27cm

Net weight: 11kg

MODEL: KB-6

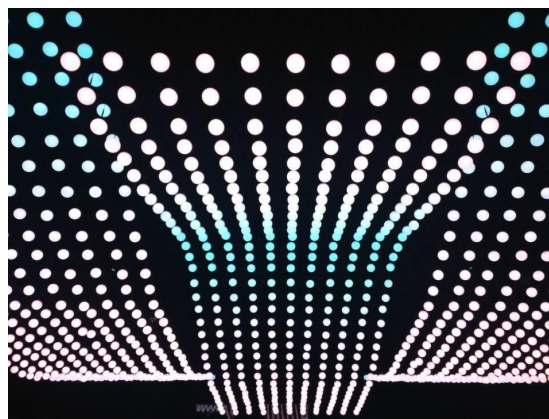
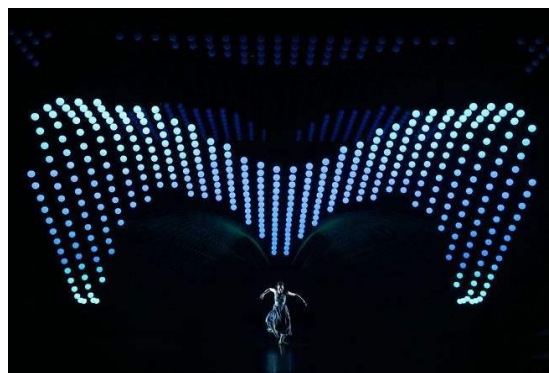

Kinetic Light is a new kind of stage equipment for event, it can be up and down by DMX controller, the speed can be select.

Specification

One winch +Led ball: 25cm

Operate Voltage:90-240v,50-60HZ;

Power :120w

Motor :3-9m

Speed:0.6m/s, speed can be adjustable

Control Channel:6/10 CH

Control Model:DMX512,Master-slave;Sound Control; Auto-run;

Work permit temperature: -5-45 degree

Light source/Effect: RGB can dimming seperately, and many strobe effect, 256 brightness control, flicker free.

G.W:9kg;

Led ball: 25CM335*395

MODEL NO.: CA440



Kinetic Tube Light is a new kind of stage equipment, it make the event more exciting. it can be up and down by DMX controller, the speed can be select and the color can be controlled by dmx controller.

Specification

One winch + LED tube

Operate Voltage:90-240v,50-60HZ;

Power :120w

Control Channel:6/10 CH

Control Model:DMX512,Master-slave;Sound Control; Auto-run;

Work permit temperature: -5-45 degree

Light source/Effect: RGB can dimming seperately, and many strobe effect, 256 brightness control, flicker free.

Classic:7.5kg;

LED tube:D5.4 *106cm

MODEL: LR760



RETRO LIGHT is new kind of decorating lighting equipment with DMX512 technology. composed by RGBW backgroup led, high powr warm white LED. it can be connecting for polygon light, widely used in night club, Bar, Church, concert, stages and other places.

Technical parameter

power supply and resource
 Power input: 100 - 240 VAC, 50 / 60 Hz
 Light source: 7X60w COB RGBW, 36x4in1 5050 led
 Rated power: 450W
 Light source life: 50000 hours
 Beam angle: 45 °

Control

Dimming: 0-100% 16bit
 Control protocol: DMX512, Auto Run, Master/slave
 DMX channel: 8CH

Connecting way

Power connection: powercon self-locking safety plug input and output
 Signal connection: three core signal input and output

appearance

Display: LCD four key display
 Protection level: IP20

Specifications

Size: 85*20*72cm
 Weight: 16kg

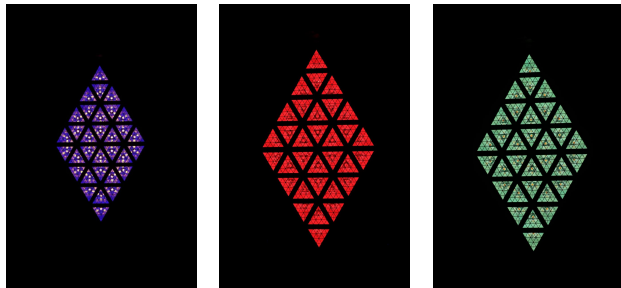

MODEL: RC1630

**Features :**

This product is a retro triangle LED special effect background light. The main light uses 16 30W 1800K golden yellow LED lamp beads, and the auxiliary light uses 576 0.3W RGB three-in-one LED lamp beads. Each main light is surrounded by 36 pieces. The lamp beads are divided into 16 modules and can be individually controlled, the effect is outstanding and vivid. This luminaire can seamlessly splice multiple luminaires or hang them for use, which can bring dazzling and multi-style effects to the stage.

This product has a good LED refresh rate, no flicker, and can be suitable for various occasions.

The lamp can be set with the signal hold function, when the signal is disconnected from the console, the current effect can be maintained

The appearance design is avant-garde, strong sense of balance, good stability effect, generous and decent, and the overall internal structure is reasonable, simple and harmonious

Specification:

- Input voltage: AC100-240V, 50/60Hz
- Light source: main light: 16 PCS 30W golden light
- Auxiliary light: 576 0.3W RGB three-in-one LED lamp beads
- Main light color temperature: 1800K (other color temperatures are optional)
- Channel: 6/12/21/64/76 CH
- Control mode: DMX512, master-slave, self-propelled, voice control
- Lamp size: 79.5x15x69cm
- Net weight: 8.3KG

can be connecting different shape

MODEL: RC660



Retro Column Light is new kind of decorating lighting equipment with DMX512 technology. composed by RGBW backgroup led, high powr warm white LED. it can be connecting for polygon light, widely used in night club, Bar, Church, concert, stages and other places.

Technical parameter

Input power supply: AC90v-240v

Power frequency: 50 / 60Hz

Power: 420W

LED resource: 6 pcs high brightness 60W LED + 144 led
3in LED

LED: RGB 3in1 LED + integrated LED

Strobe: 1-25 times / second



Control

Dimming: 0-100% 16bit

Control protocol: DMX512, Auto Run, Master/slave

DMX channel: 8/28CH

Connecting way

Power connection: powercon self-locking safety plug input and output

Signal connection: dmx 3 pin input and output

appearance

Display: LCD four key display

Protection level: IP20

Heat dissipation mode: metal heat conduction

Maximum operating ambient temperature: 45 °C

Specifications

Size: 156x22x21mm

Weight: 11.5kg

MODEL: RC350



RETRO LIGHT is new kind of decorating lighting equipment with DMX512 technology. composed by RGBW backgroup led, high powr warm white LED. it can be connecting for polygon light, widely used in night club, Bar, Church, concert, stages and other places.

Technical parameter

power supply and resource

Power input: 100 - 240 VAC, 50 / 60 Hz

Light source: 3X50w COB RGBW, 36x 3in1 5050 led

Rated power: 200W

Light source life: 50000 hours

Beam angle: 45 °

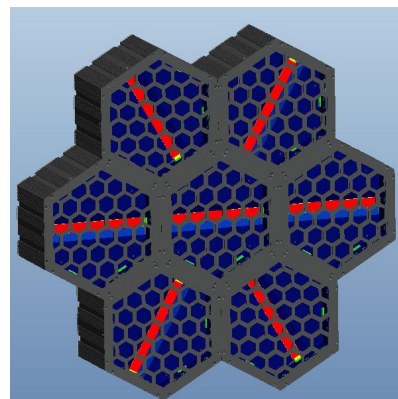
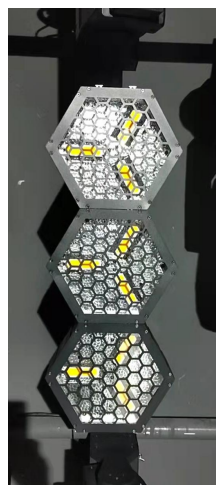

can be connecting different shape

Control

Dimming: 0-100% 16bit

Control protocol: DMX512, Auto Run, Master/slave

DMX channel: 8CH

Connecting way

Power connection: powercon self-locking safety plug input and output

Signal connection: three core signal input and output

appearance

Display: LCD four key display

Protection level: IP20

Function

Hexagon shade can be connecting for polygon model light

Specifications

Size: 32x21x21mm

Weight: 6.5kg

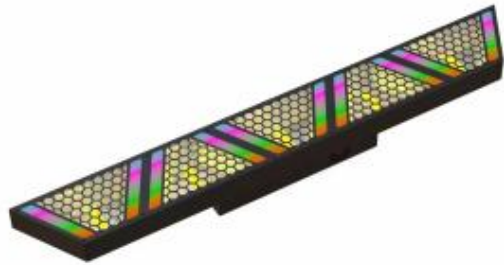
MODEL: RC550

RETRO LIGHT is new kind of decorating lighting equipment with DMX512 technology. composed by RGBW backgroup led, high powr warm white LED. it can be connecting for polygon light, widely used in night club, Bar, Church, concert, stages and other places.

Technical parameter

power supply and resource

Power input: 100 - 240 VAC, 50 / 60 Hz

Light source: 5X50w COB RGBW, 90x 3in1 5050 led

Rated power: 260W

Light source life: 50000 hours

Beam angle: 45 °

Control

Dimming: 0-100% 16bit

Control protocol: DMX512, Auto Run, Master/slave

DMX channel: CH11,CH35,CH42,CH04

Connecting way

Power connection: powercon self-locking safety plug input and output

Signal connection: 3pin signal input and output

appearance

Display: LED four key display

Protection level: IP20

Function

Hexagon shade can be connecting for polygon model light

Specifications

Size: 1118*146*157mm

Weight: 5.5kg

MODEL: TB3100



TRI-BLINDER LIGHT is new kind of LED strobe light with background lighting effect, and come with pixel ring effect. Good for using in background of stage, DJ, concert events.

Technical parameter

power supply and resource

Power input: 100 - 240 VAC, 50 / 60 Hz

Light source: 3X100w COB, 5050 3 in1 led

Rated power: 300W

Light source life: 50000 hours

Beam angle: 45 °

Control

Dimming: 0-100% 16bit

Control protocol: DMX512, Auto Run, Master/slave

DMX channel: 9/14CH

Strobe: 0-25 t/s,

Connecting way

Power connection: powercon self-locking safety plug input and output

Signal connection: 3pin signal input and output

Specifications

Size: 32x21x21mm

Weight: 6.5kg

MODEL: BC615



- Input voltage: AC100v-250v / 50-60Hz
- Power: 120W
- Light source: 6 x 15W high brightness OSRAM led (4 in 1)
- Color: 16.7 million color changes
- Waterproof grade: IP65
- Light source life: 50000 hours
- Lens angle: 40 ° Control: DMX512, master-slave control, self-propelled, stroboscopic, infrared remote controller
- Battery: 18650 lithium battery 21600 mah capacity, long time standby.
- Charging and discharging can reach more than 500 times
- Charging time: 8 hours full charge
- Discharge time: RGBW is fully bright for 3.5 hours, monochromatic for 10 hours
- Auto Run mode 9.5 hours
- Inflating to start up in 1 minute

Characteristics

- all aluminum body heat dissipation,
- uniform light emission
- Design of waterproof structure of base
- Waterproof soft light emitting cloth material (can be customized pattern, logo)
- laser marking of aluminum base (can customize the pattern and logo)
- Optical modulation technology with UHF (64khz), flicker free
- Size: 4600mm diameter * 3200mm high
- Net weight: 8kg

MODEL NO.: FS-400



400 LED Follow Spot Light is a new 400w bright LED follow light, it is composed of 1x 400 Watt LED. It comes with an iris, color wheel, and dimmer effect. It is suitable for use on stage, in concert halls, at weddings, and for any entertainment events.

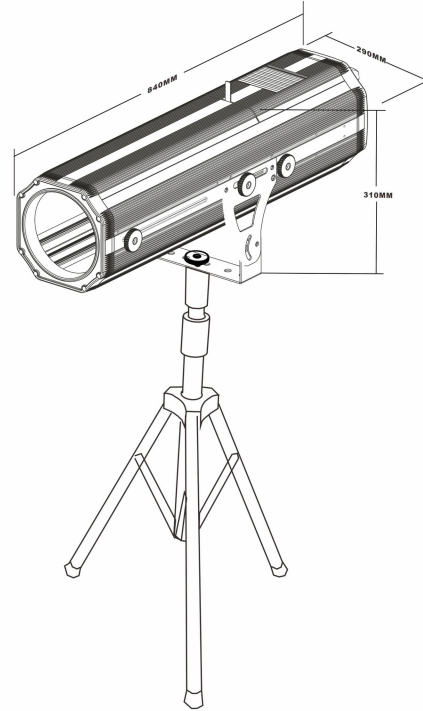

Technical Specifications:

- POWER: AC 90-240V 50Hz/60Hz
- LIGHT SOURCE: 400w led
- POWER CONSUMPTION: 450W
- Beam angle: 3° - 15° adjustable
- Spot distance: 60-70M
- 4 colors + open, with dimmer. can zoom.
- Lux: high brightness 20M/3600LUX
- Manual control, easy use
- Convection cooling-fan, optimize internal air duct way, heat elimination rapidly
- According to various kinds of safety standards,
- IP20 protect grade
- As well as the stage, multi-functional studio and disco, wedding ceremony.
- FIXTURE DIMENSION: L830 × W260 × H220(mm)

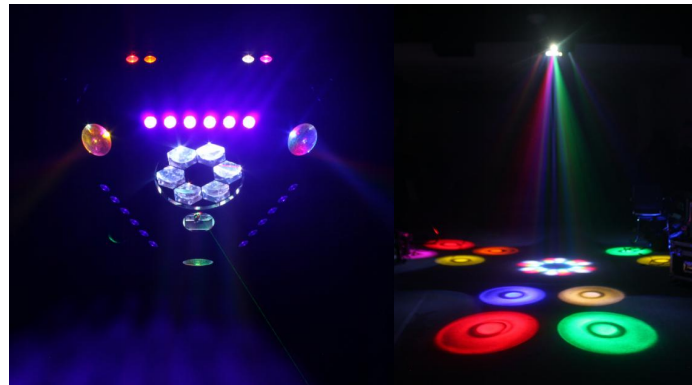
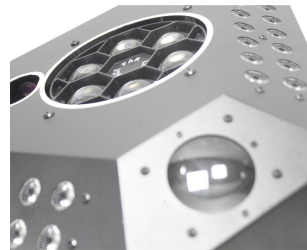

MODEL: DISCO-USFO

**Feature**

UFO disco Light is combine with bubble, bee beam, been, UV, red and green laser effect. There is auto run in program, sound active and DMX512 control working mode. With exciting effect, it only need one piece of the light decorating for your party, disco, KTV, not need much lighting device.

Specification

Voltage: AC110/220V 50-60HZ

Source: Strobe 3W LED*18PCS

Bubble: 3W* 6pcs

Bee beam: 10WLED*6PCS

Beam: 10W*12PCS

UV: 3W*24PCS

Red laser: 100MW

Green laser: 50MW

Power: 320W

Control mode: Auto run in program, Sound active , DMX512,
size: 46*40*12cm

packing size: 55*53*42cm 2PCS/CTN (19.8kg)

MODEL: KTV-5

**Feature:**

3-Head Disco Light is composed with 3 head which can be shoot out laser and colorful beam effect. It has DMX 512 mode, Auto run and sound active mode. with multi-functionm, one small party only need one device for it.

Specification

Voltage: AC110/220V 50-60HZ

Source:10W*18PCS

Power: 200W

Red laser:100MW

Green laser: 100MW

Blue laser: 500MW

Auto, Sound , DMX512,

Net weight:5.9KG size:37*37*37.5cm

packing size:88*46*37 2pcs/ctn (16.5KG)

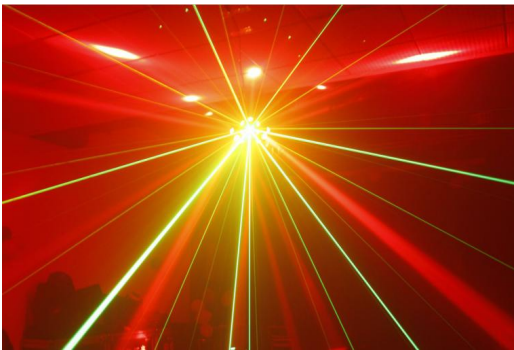

MODEL: KTV-1

**Feature**

Moving head disco Light is combine with led strobe parallel beam and laser beam effect, the effects can be changeable. There is auto run, sound active and DMX512 control working mode. With exciting effect, it only need one piece of the light decorating for your party, disco, KTV, not need much lighting device.

Specification

Voltage: AC110/220V 50-60HZ

power: 250W

Light source:18pcs*10W Cree 4in1 LED RGBW

red laser: 100MW*2pcs

green laser: 50MW*2pcs

Channel: 15/25CH

Movement: Pan 540° , Tilt: infinitely 360°

Control mode: Auto run program, sound active ,DMX512,

Effect: there are 18 beams, and 2 laser , which the colors change be changed,

the speed rotating can be adjusted.

Net weight:5.5kg

Gross weight:7kg

Size:35*21*35cm

Packing size:59*42*46cm 2PCS/CTN (15KG)

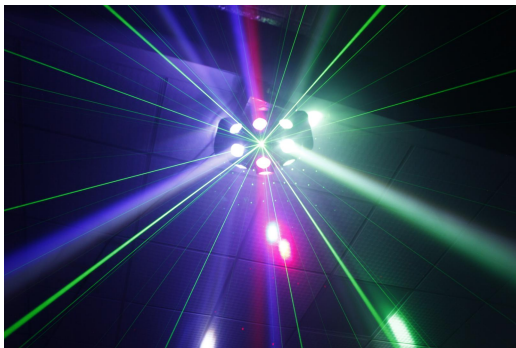

MODEL: KTV-3

**Feature**

Small Disco Light is 16 pieces 3 watts Green Laser Light. There is auto run in program, sound active and DMX512 control working mode. With exciting effect, it only need one piece of the light for decorating your party, disco, KTV, not need much lighting device.

Specification

Voltage: AC110/220V 50-60HZ

Light Power: 50W

CRI(Ra>):85

Light Source:LED

HZ Source:3W*16PCS

Green laser:50MW

Emitting color:RGBW

Control Mode:Auto, Sound, DMX512

Working lifetime:50000h

IP Rating:IP33

Warranty(year):1 year

Working temperature:-45 to 45 degrees

Product Size:26*26*19cm

Net weight:2.65KG

Packing Way:6PCS/CTN

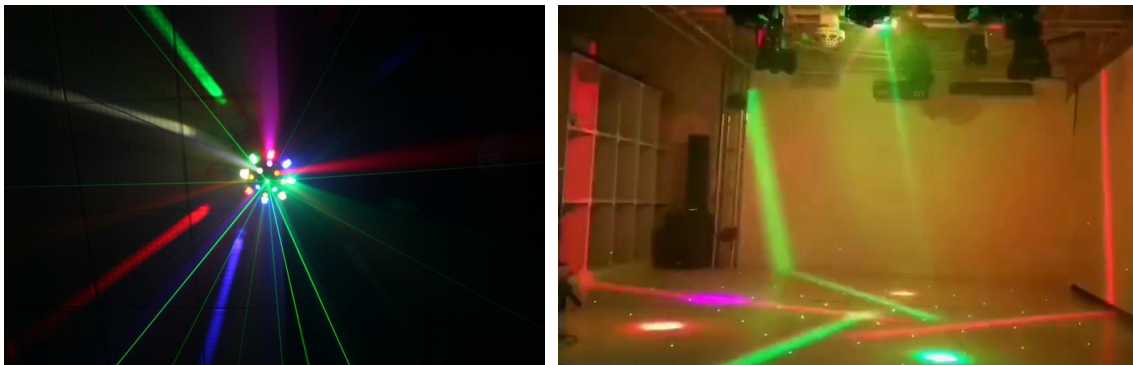

MODEL: KTV-2

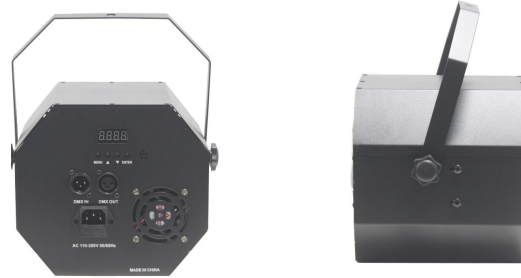
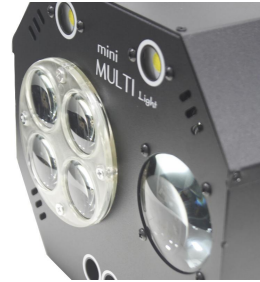
**Feature**

Mini Multi-function disco Light is combine with 4 spot, 4 gobo, red laser and green effect, the effects can be changeable. There is auto run, sound active and DMX512 control working mode. With exciting effect, it only need one piece of the light decorating for your party, disco, KTV, not need much lighting device.

Specification

Voltage: AC110/220V 50-60HZ

power: 30W

Light source:8pcs*3W led(RGBW color)

red laser: 100MW

green laser: 50MW

Channel: 9CH

Control mode: Auto run program, sound active ,DMX512,

Effect: there are bubble, gobo, and 2 laser , which the colors change be changed,

the speed rotating and strobe is adjustable.

net weight: 1.75KG

gross weight: 2.2kg

Size:19*13*16cm

packing size:49*39*58cm 8pcs/ctn (18.6kg)

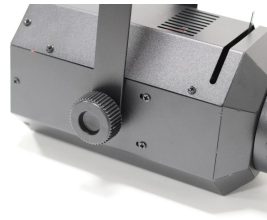

MODEL: KTV-59

**Feature**

KTV-59 Mini Spot light is composed of 30W or 60W LED, warm white or RGBW four-in-one, high-definition lens, a clear light circle, manual iris can adjust the size of the spot, suitable for bars, slow shake bars or cultural tourism venues .

Specification

Power supply: AC110/220V 50-60HZ

Light source: 30W COB /60W COB

Beam angle 17-18 degrees

Power: 30W (white/warm white)

60W (red, green and blue)

Control method: manual, DMX512

Net weight: 2.15KG

Gross weight: 2.6KG

Inner packaging: 35*18*19CM

Outer packing: 57*37*41CM 6 pieces in one pack



MODEL: HZ600

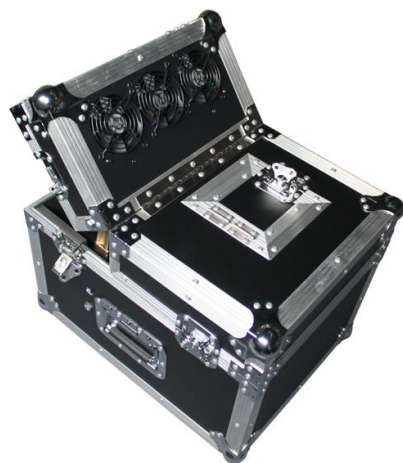

300/600 Haze machine is the company independently designed a special effects fog machines, for professional lighting showrooms, Bars, KTV, night clubs, theater particularly laser light, beam lights, LED lights place, More in need of such equipment. It has the following

Technical Parameters

Voltage : AC 220-240V 50/60Hz
AC100-120V 50/60Hz

Power : 600w/300W

Smoke oil capacity : 1.2 L

Control : digit display, DMX512

N.W : 7.5kg/18kg

G.W : 8.5kg/30kg

Product Size : 31*29*28cm (HZ300)

52*40*45cm (HZ600)

Package Size : 39*26.5*28.5cm

characteristics:

- No need Pre-heating, the use of special oil mist
- fuel-efficient, one liter of oil can work for 20 hours
- Drying: Despite long hours of work, no moisture, oil particles, will not cause the lights set Preparation of the
- residual oil
- uniform: smoke uniform, delicate, fast diffusion
- no smell: smoke is colorless and odorless, the oil mist can be added in any oily flavor
- Producing even light haze, low noise, no burnt odor, no harm to the optic;
- Fluid tank with exclusive anti-slip and anti-leaking safety design prevents spills during machine transportation;
- Low fluid consumption rate, small size and convenient to use;
- Built-in digit control panel, and allow DMX-512 signal control.

MODEL: HZ300

Price: 140USD



MODEL : C-Z12



SPECIFICATION:

Rated voltage: AC110 ~ 130v or

AC220 ~ 240V , 50 ~ 60Hz

Rated power: 1500W

Control mode: wire control, remote control

Smoke oil capacity: 3L

Smoke spraying distance: 8M

Initial preheating: 7 minutes

Smoke emission: 10000cuff / min

Working environment: indoor: 0 °C ~ 40 °C

Temperature control mode: electronic constant temperature

Appearance: metal shell, multilateral design

Protection grade: IP20

Smoke spraying direction: 0 ° ~ 90 ° , which can be set arbitrarily



fog liquid

MODEL : C-256



SPECIFICATION:

- DMX channel : 768
- Fixture : 32
- Channels for each fixture : 24
- Playback : 60
- Playbacks to run simultaneously : 12
- Chase step : 120
- Time control of playbacks : Fade in/out, LTP slope
- Built-in Shape : 135
- Shape for each scene/Step : 5
- Playback and dimmer by slider : Support
- Interlocked playback : Support
- Shape generator : Shapes of Dimmer, Pan/Tilt and RGB
- Shapes to run simultaneously : 5
- Channel type setup : Yes. For shape enabling
- Real time blackout : Yes
- Power supply : 9V/12V DC adapter
- Power consumption : 12 Watt
- Net. Weight : 4KG
- Weight in Carton : 5KG
- Weight in Flight Case : 11KG
- Product size: 480*230*90
- Power supply: AC 100 -240V / 50-60Hz.

MODEL: 1024 Cosole



- DMX512/1990 standard maximum 1024 DMX control channels, photoelectric isolation signal output.
- Maximum control of 96 computer lights or 96 channels of dimming using the pearl lamp library.
- The built-in graph track generator has 135 built-in graphs, which is convenient for users to control the graph track of the fixture, such as drawing, spiral, rainbow, chase and other effects. The graph parameters (Xo: amplitude speed, interval, wave, direction) are all Can be set independently.
- 60 replay scenes, used to store multi-step scenes and single-step scenes, multi-step scenes can store up to 600 steps.
- LCD display with backlight display in Chinese and English.
- Support U disk backup and upgrade, automatically save data when shutdown.
- Power supply: AC 90-240V/50-60Hz switching power supply
- Dimensions: 485x420x105mm

MODEL: TT



Rated voltage:110v~220v , 50~60hz

Powerful titan operating system

intel Core Dual processor

60G solid state drive.

2Gmemory

Built-in a 15.4 inch touch screen, can extend to a 17 inch touch screen.

12 DMX universes:4 physical DMX outputs and expand to 12 by a Ethernet output.

6144 channels

10 direct macro buttons and macro library.

20 Submasters for cues, cue lists and chases.

1000 Virtual playback Executors.

Support of Artnet, Avotalk, and CITP protocols.

Strong CMY palette function.

can be remote controlled using wi-Fi from a mobile internet device (like Iphone, Ipod Touch etc.)

Built-in thousands of fixture library and its edit software.

Built-in Visualiser software.

Support of multi-media(video)via CITP.

The version software 9.1

N.W:14kg

Gross weight:30kg

Dimensions:68x43x15CM

Package size:78x53x32cm

MODEL: Quartz



Specification:

14.1 inch screen, 10.0 system, with ups power supply. The default output is 4 DMX512, and the network can output 12 DMX512

Technical parameter configuration:

Intel dual-core processor, 120G SSD, 90 minutes ups power supply.

Built-in 4 DMX output ports, 2048 channels;

Support Art-net network output, which can be expanded to 12 Universe DMX outputs through the network;

Support Titan-net protocol, expandable to 64 Universe DMX outputs

10 mechanical page-turning playback faders;

20 custom macro function keys

Built-in a 14.1" high-brightness touch screen,

Expandable with one Titan Fader wing (playback aux, 20 playback faders, 30 custom macro functions, USB powered)

Support headphone output (Headphone)

1 Gigabit network interface, support Art-net, Titan-net, Streaming ACN protocol

Compatible with other TITAN system console show files

Product Dimensions: 425 x 466 x 194 (LxWxH)

Weight: 23KG

MODEL NO.: P2/P2-PRO



MODEL NO.: P2-RGB PRO

**Technical parameter**

- light grandma2
Linux system. Latest Software Version.
- Two 15.4-inch electric lifting touch display screens, one 9-inch touch screen.
- i7CPU, 8G RAM, 128G SSD. Geforce graphics cards.
- 7 DMX output/input ports. The connection with NPU can support up to 65536 channels.
- 15 high-precision electric faders, 50 buttons for executing programs.
- 1 master fader, 1 dimming wheel.
- 1 controllable XY axis high precision imported imported trackball.
- 2 A/B field electric putters. 6 imported industrial grade wearable encoders (with Push function).
- 2 Gigabit Ethernet ports, support MA NET, ARTNET and other signals.
- 5 USB ports. 2 work light interfaces.
- MIDI input and output interface. SMPTE/LTC interface.
- Built-in 1 drawer, built-in yellow backlit mechanical keyboard (backlight brightness adjustable).
- Wide voltage industrial power supply 100V-240V 50/60Hz.
- Built-in high-power UPS.
- Support RDM function.

MODEL NO.: MA3

**Technical parameter**

- : Professional Linux OS
- : Built-in 3 electric lift 15.4-inch industrial full-view touch screens, 1 9-inch industrial full-view touch screen
- : ASUS motherboard, powerful i5CPU, 4G memory, built-in solid state drive, 2 Geforce graphics cards
- : 6 DMX output ports, 1 composite DMX input port (can be set as output), and can support up to 65536 channels when connected to NPU
- : 30 electric replay faders (60mm) with induction function, 80 execution program buttons
- : 1 master fader
- : 2 A/B fader (100mm)
- : 7 imported industrial-grade wear-resistant encoders (with Push function)
- : 1 dimming wheel
- : 1 controllable XY-axis high-precision imported trackball
- : 2 Gigabit Ethernet ports, support MA NET, ARTNET, ETC NET2, PATHPORT, SCAN, SHOWNET, KINET1 signals
- : 5 USB ports, 1 backup USB port
- : 2 desk light interfaces
- : 2 DVI ports, expandable for two displays
- : MIDI input and output interface, LTC/SMPTE time code, audio input and output, microphone input interface
- : Built-in 2 drawers
- : Built-in push-pull professional yellow backlit mechanical keyboard (backlight brightness adjustable)
- : Yellow backlit mechanical keys (backlight brightness adjustable)
- : Wide voltage industrial power supply 100V-240V 50/60Hz
- : Built-in high-power UPS uninterruptible power supply
- : Support RDM function

MODEL NO.: MA-NPU



Technical parameter

The NPU has the same CPU as the console.

i5CPU, 4G RAM, 128G SSD.

It has powerful computing ability to convert network signals to DMX signals.

Built-in 4,096 channels of 8 DMX output ports.

Built-in a 7-inch TFT touch display.

1 Gigabit Ethernet interface. 2 USB 2.0 connection ports.

Multiple MA controllers can share one or more NPUs to achieve hot backup.

Multiple NPUs can be connected in series. Support protocols such as DMX512, ART-NET and ACN.

Support RDM function.

MODEL NO.: MA-COMMUND WING



Technical parameter

2048 parameters can be controlled in real time

6 playback (60mm long), 18 playback buttons

2 A/B switch faders (length 100mm) 6 execution buttons, 6 page buttons (channel/fader/button) 4 encoding wheels

2048 parameters, up to 4096 parameters

2DMX output port, 1DMX input port

1 brightness dimming wheel

Dimmable Silent Buttons with Independent Backlight

Analog signal remote control input interface

LTC jacks, MIDI IN and MIDI OUT jacks

USB2.0 interface

Wide voltage (100-240VAC) power supply is lightweight. Portable and sturdy, weighing only 6KG

The layout of the command keypad is similar to that of the console; plug and play, just connect to a PC to easily

implement the functions of the console

Volume: 63*57*26cm

Gross weight: 12KG



Website: <https://en.ledstagelight.cn/>
Tel / WhatApp/Wechat: +86 13660106772